

Description

General

The transceiver is small form factor pluggable module for serial optical data communications such as IEEE 802.3ae 10GBASE-ZR. It is with the SFP+ 20-pin connector to allow hot plug capability. It designed expressly for high-speed communication applications that require rates up to 10.3Gb/s, and to be compliant with SFF-8472 SFP+ MSA. Digital diagnostic functions are available via an I2C. This module is designed for single-mode-fiber (SMF) and operates at a nominal wavelength of 1550nm.

Transmitter Section

The transmitter consists of a high-performance 1550 nm EML-DFB laser module in the optical subassembly (OSA), which is housed within a metal box package. In addition, this component is also class 1 laser that compliant with International Safety Standard IEC-60825-1 and FDA 21 CFR 1040.10 and 1040.11.

Receiver Section

The receiver contains of an InGaAs APD that coupled to a high sensitivity transimpedance amplifier (TIA) in an OSA. This OSA combination is mated to a post amplifier IC that provides the post amplification SD (Signal Detection) or LOS (Loss of Signal) indication circuit which provides the logic high state output when an unusable input optical signal level detected.

SFP+ Duplex SMF Transceiver	
LC Type with DDM	SY15A0-80ATKZ(WT)

Features

- Single +3.3V Power Supply
- Compliant with SFP+ MSA
- Compliant to IEEE 802.3ae 10GBASE-ZR/ZW
- SFF-8472 Digital Diagnostic Function
- AC/AC Coupling according to MSA
- Class 1 Laser International Safety Standard IEC-60825-1:2014 Compliant. Complies with EN60825-1:2014/A11:2021 and FDA 21 CFR 1040.10 and 1040.11
- Industrial Operation Temp.: -40 °C to +85 °C
- RoHS Compliant

Applications

- High-speed Storage Area Networks
- Computer Cluster Cross-connect
- Custom High-speed Data Pipes
- 10G Ethernet Links

Performance Specifications

Absolute Maximum Ratings						
Parameter	Symbol	Min	Typ	Max	Unit	
Supply Voltage	V _{CC}	-0.5	-	4.5	V	
Storage Temperature	T _s	-40	-	85	°C	
Operating Case Temperature	Commercial	T _{OP-com}	0	-	70	°C
	Industrial	T _{OP-ind}	-40	-	85	°C
Operating Humidity	-	5	-	85	%	
General Specifications						
Parameter	Symbol	Min	Typ	Max	Units	
Data Rate	B	1.0	10.3	10.7	Gbps	
Supported Link Length on 9/125μm SMF	L	-	80	-	km	
Supply Current	I _{CC}	-	-	600	mA	

Optical and Electrical Characteristics

Transmitter Electrical Characteristics					
Parameter	Symbol	Min	Typ.	Max	Unit
Supply Voltage	V_{CC}	3.135	3.3	3.465	V
Data Differential Input Voltage	$V_{in, pp}$	180	-	850	mVpp
Input Differential Impedance	Z_{in}	90	100	110	Ω
TX Enable input voltage	V_{IH}	2.0	-	V_{CC}	V
TX Disable input voltage	V_{IL}	0	-	0.8	V
TX Fault Voltage-High (Fault)	V_{TF}	2.0	-	V_{CC}	V
TX Fault Voltage-Low (Normal)	V_{TN}	0	-	0.8	V
Transmitter Optical Characteristics					
Parameter	Symbol	Min	Typ.	Max	Unit
Output Optical Power	P_O	0	-	+5	dBm
Center Wavelength	λ_C	1530	1550	1570	nm
Spectral Width (-20dB)	$\Delta\lambda_{(-20dB)}$	-	-	1	nm
Side Mode Suppression Ratio	SMSR	30	-	-	dB
Extinction Ratio	ER	3.5	-	-	dB

*Measured with a PRBS 2³¹-1 test pattern @10.3125 Gbps.

Receiver Electrical Characteristics					
Parameter	Symbol	Min	Typ.	Max	Unit
Supply Voltage	V_{CC}	3.135	3.3	3.465	V
Data Differential Output Voltage	$V_{out, pp}$	300	-	900	mV
Receiver LOS/SD Output Voltage-High	V_{RH}	2.0	-	V_{CC}	V
Receiver LOS/SD Output Voltage-Low	V_{RL}	Gnd	-	0.8	V
Receiver Optical Characteristics					
Parameter	Symbol	Min	Typ.	Max	Unit
Maximum Receiver Power	P_{in}	-8	-	-	dBm
Receiver Sensitivity	P_S	-	-	-24	dBm
Optical Center Wavelength	λ_C	1260	-	1600	nm
Signal Detect-Asserted	P_A	-35	-	-	dBm
Signal Detect-Deasserted	P_D	-	-	-25	dBm
Signal Detect-Hysteresis	P_A-P_D	0.5	-	-	dB

*at BER=10⁻¹² and PRBS 2³¹-1.

Timing and Electrical Characteristics

Parameter	Symbol	Min	Typ.	Max	Unit
TX Disable Negate Time	t_on	-	-	1	ms
TX Disable Assert Time	t_off	-	-	10	µs
Time to initialize, including Reset of TX Fault	t_init	-	-	300	ms
TX Fault Assert time	t_fault	-	-	100	µs
TX Disable to Reset	t_reset	10	-	-	µs
LOS Assert time	t_loss_on	-	-	100	µs
LOS De-assert time	t_loss_off	-	-	100	µs
Serial ID clock rate	f_serial_clock	-	100	400	KHz
MOD_DEF (0:2)-High	V _H	2	-	V _{CC}	V
MOD_DEF (0:2)-Low	V _L	-	-	0.8	V

Digital Diagnostic Monitor Accuracy

Parameter	Typical Value	Note
Transceiver Temperature	± 3°C	T _{OP-min} ~ T _{OP-max}
Power Supply Voltage	± 3%	V _{CC}
TX Bias Current	± 10%	
TX Optical Power	± 3dB	P _{O-min} ~ P _{O-max}
RX Optical Power	± 3dB	P _S ~ P _{in}

Transceiver functional Diagram

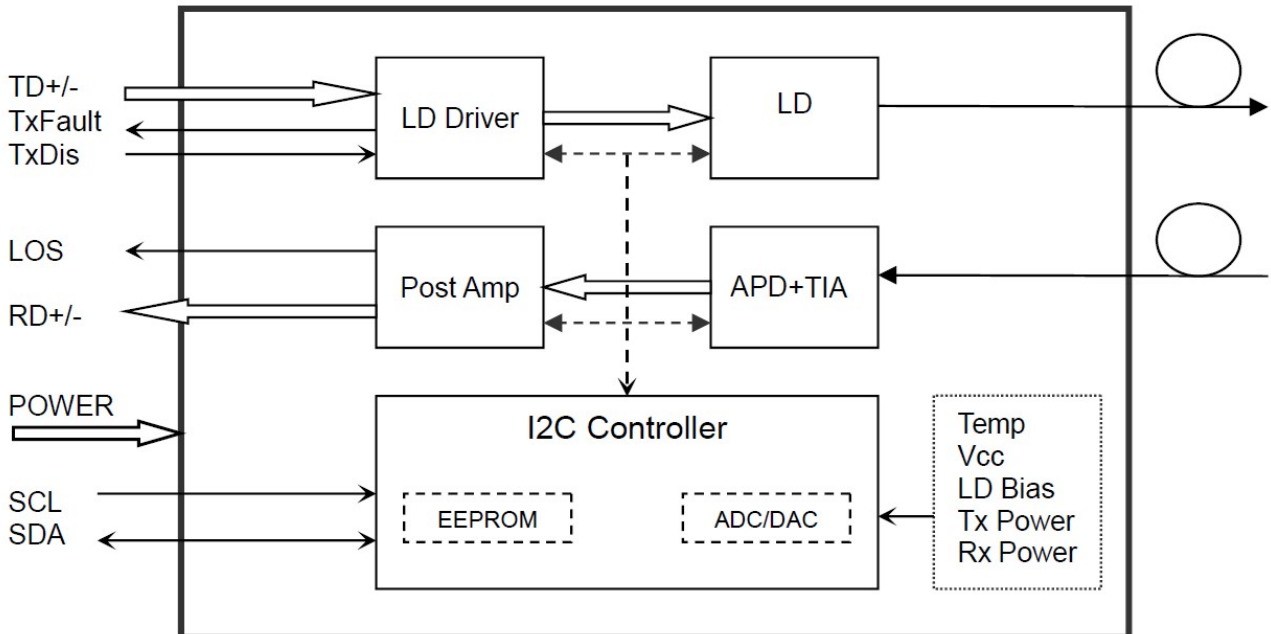

Ordering Information

SY 15 A0 – 80 A T K Z(WT)

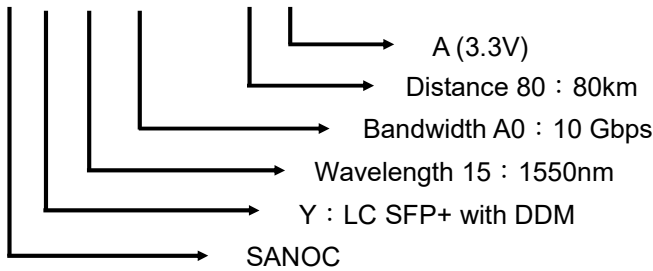

Recommended Circuit Schematic

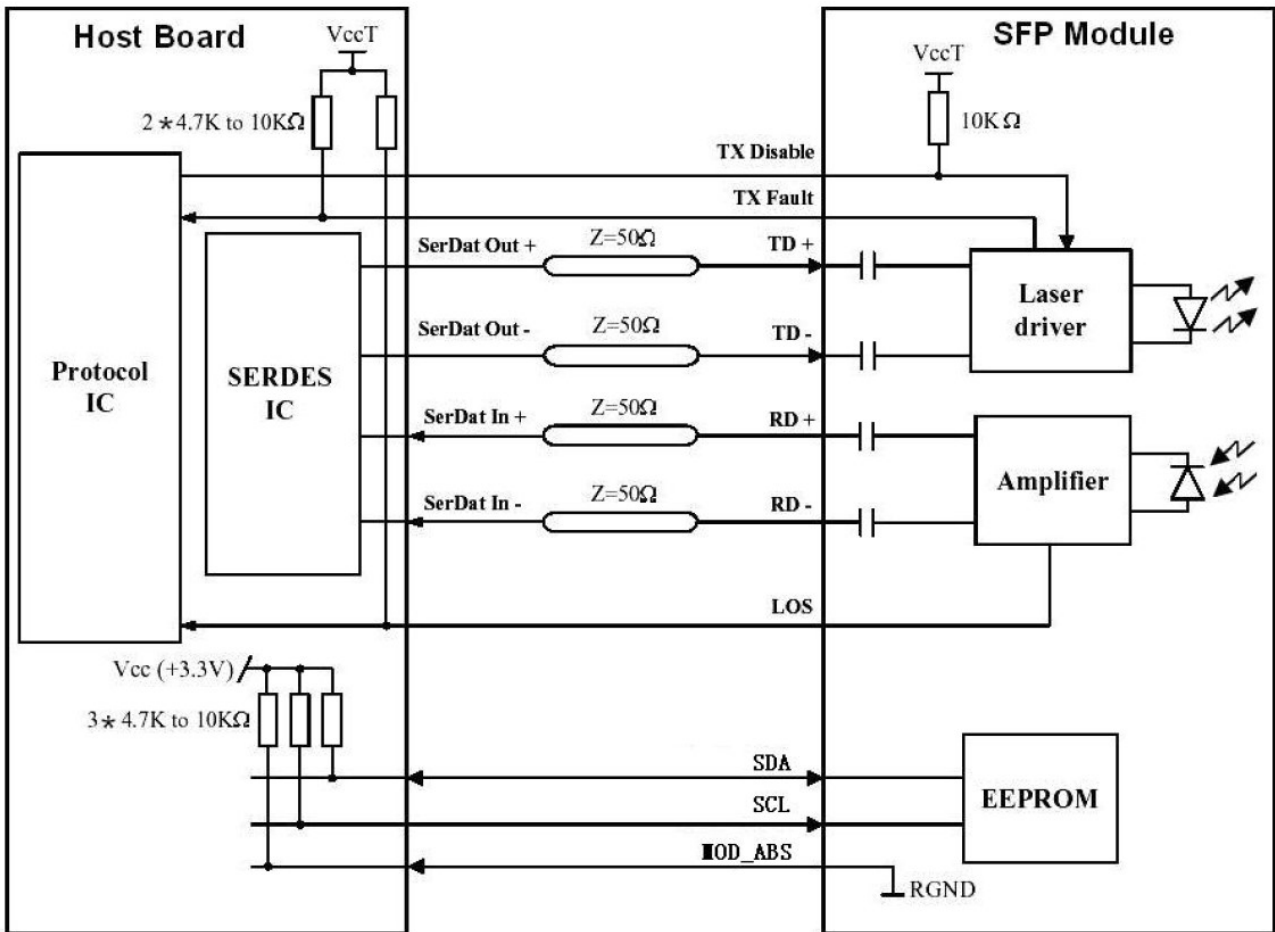

SFP+ Transceiver Electrical Pad Layout

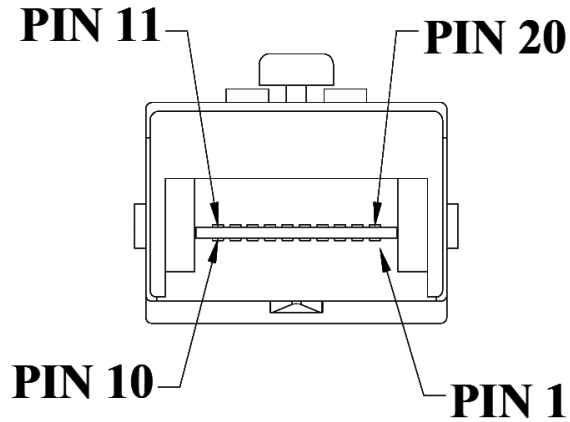
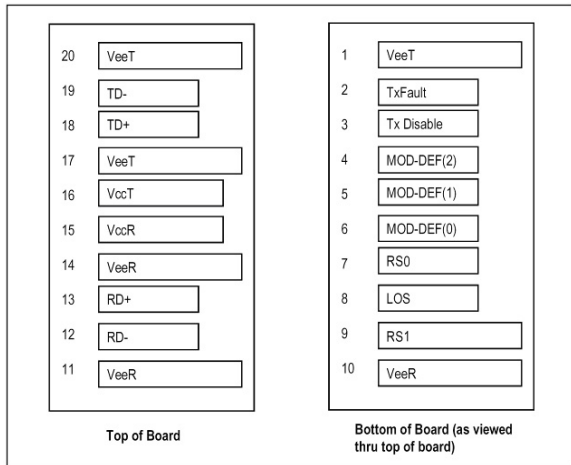

Pinout Table

Pin	Symbol	Name/Description	Ref.
1	V _{EET}	Transmitter Ground	
2	T _{FAULT}	Transmitter Fault indication	3
3	T _{DIS}	Transmitter Disable	1
4	MOD_DEF (2)	Module Definition 2. Data line (SDA) for Serial ID.	2
5	MOD_DEF (1)	Module Definition 1. Clock line (SCL) for Serial ID.	2
6	MOD_DEF (0)	Module Definition 0. Grounded within the module.	2
7	RS0	Not Connected	
8	LOS	Loss of Signal indication	3
9	RS1	Not Connected	
10	V _{EER}	Receiver Ground	
11	V _{EER}	Receiver Ground	
12	RD-	Receiver Inverted DATA out. AC Coupled	
13	RD+	Receiver Non-inverted DATA out. AC Coupled	
14	V _{EER}	Receiver Ground	
15	V _{CCR}	Receiver Power Supply	
16	V _{CCT}	Transmitter Power Supply	
17	V _{EET}	Transmitter Ground	
18	TD+	Transmitter Non-Inverted DATA in.	
19	TD-	Transmitter Inverted DATA in.	
20	V _{EET}	Transmitter Ground	

Notes:

1. Laser output disabled on TDIS >2.0V or open, enabled on TDIS <0.8V.
2. Should be pulled up with 4.7k – 10kohms on host board to Vcc.
3. TX-Fault and LOS are open collector output. Should be pulled up with 4.7k – 10k ohms on host board to Vcc.

Memory map

The memory map in the following describes an extension to the memory map defined in SFP MSA. The enhanced interface uses the two wire serial bus address 1010001X(A2h) to provide diagnostic information about the module's present operating conditions.

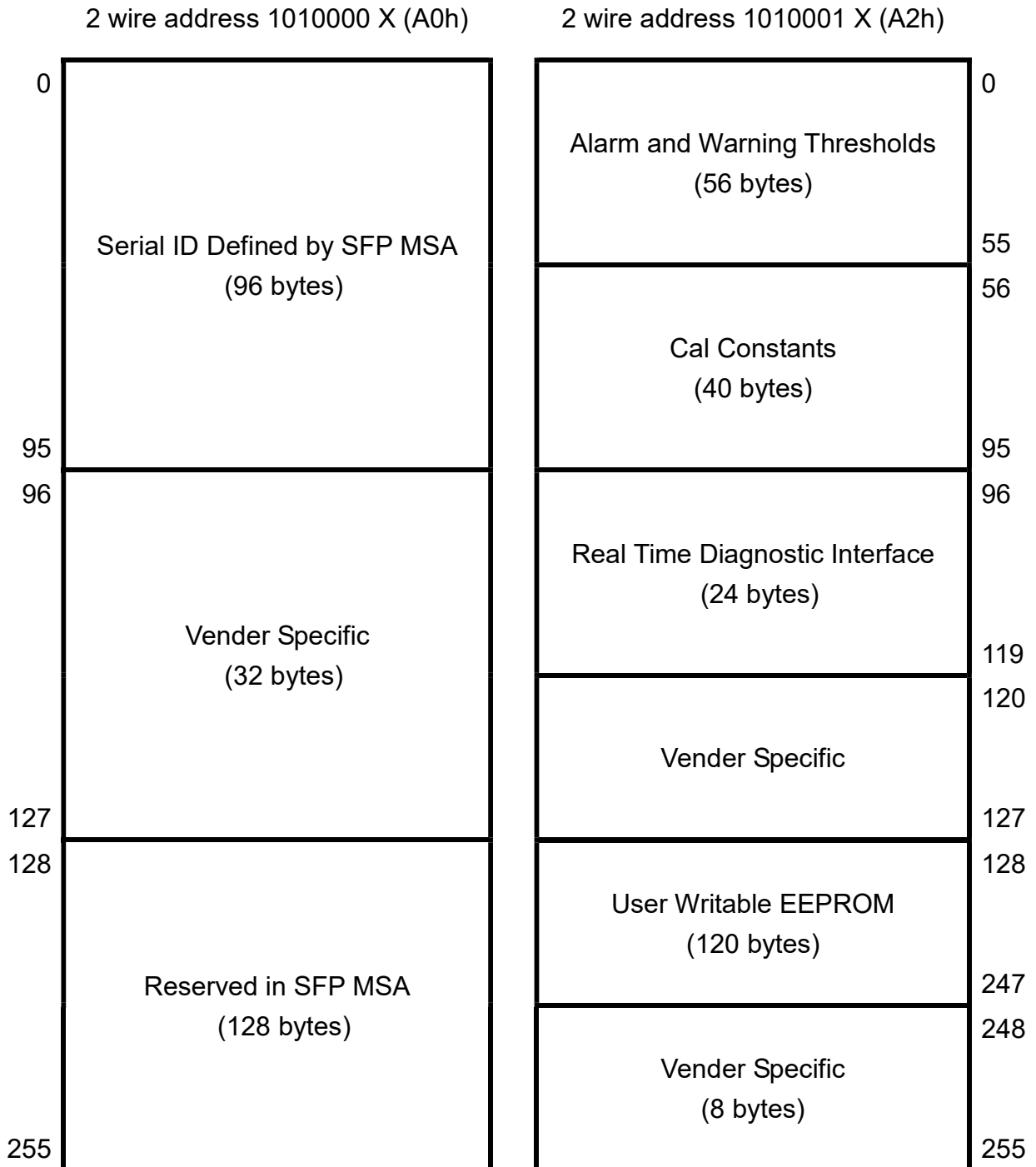

Package Outline Drawing

LC Type (SY Series)

DIMENSIONS ARE IN MILLIMETERS (unit:mm)

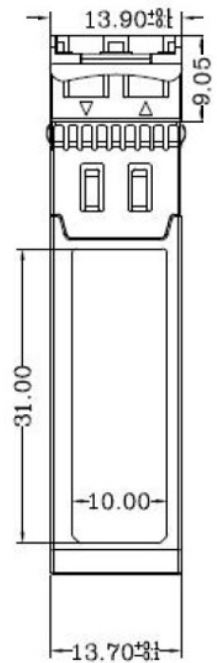
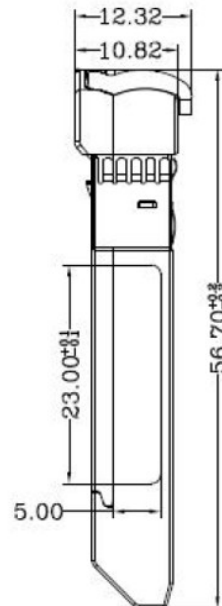
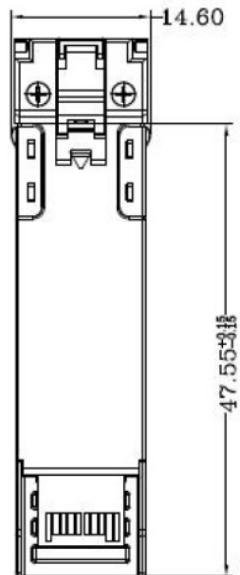
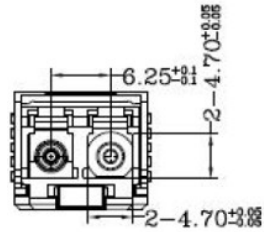

SFP host board mechanical layout

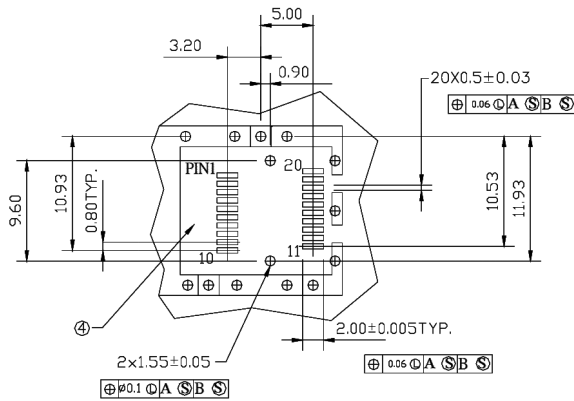
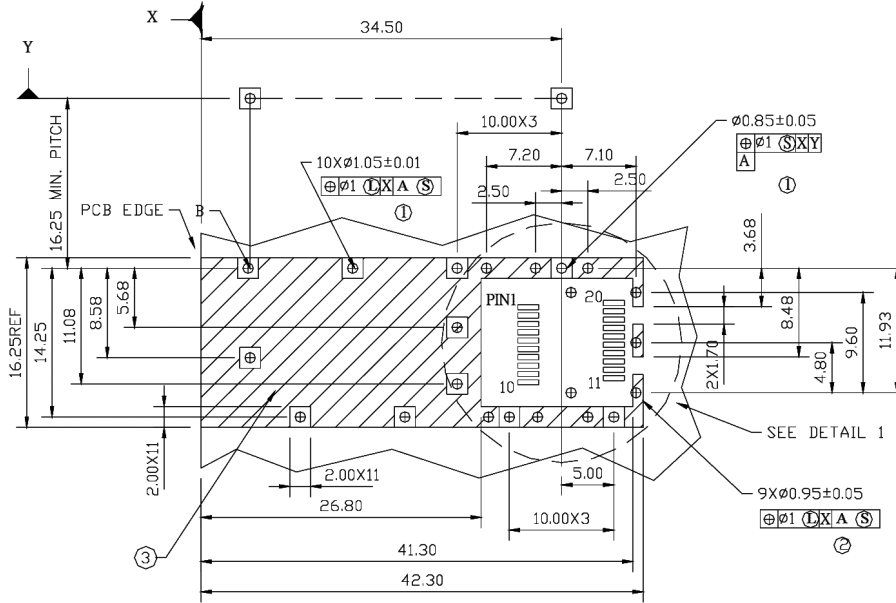

DETAIL 1

LEGEND

- 1.PADS AND VIAS ARE CHASSIS GROUND
- 2.THROUGH HOLES, PLATING OPTIONAL
- 3.HATCHED AREA DENOTES COMPONENT AND TRACE KEEPOUT(EXCEPT CHASSIS GROUND)
- 4.AREA DENOTES COMPONENT KEEPOUT (TRACES ALLOWED)

DIMENSIONS ARE IN MILLIMETERS

Assembly drawing

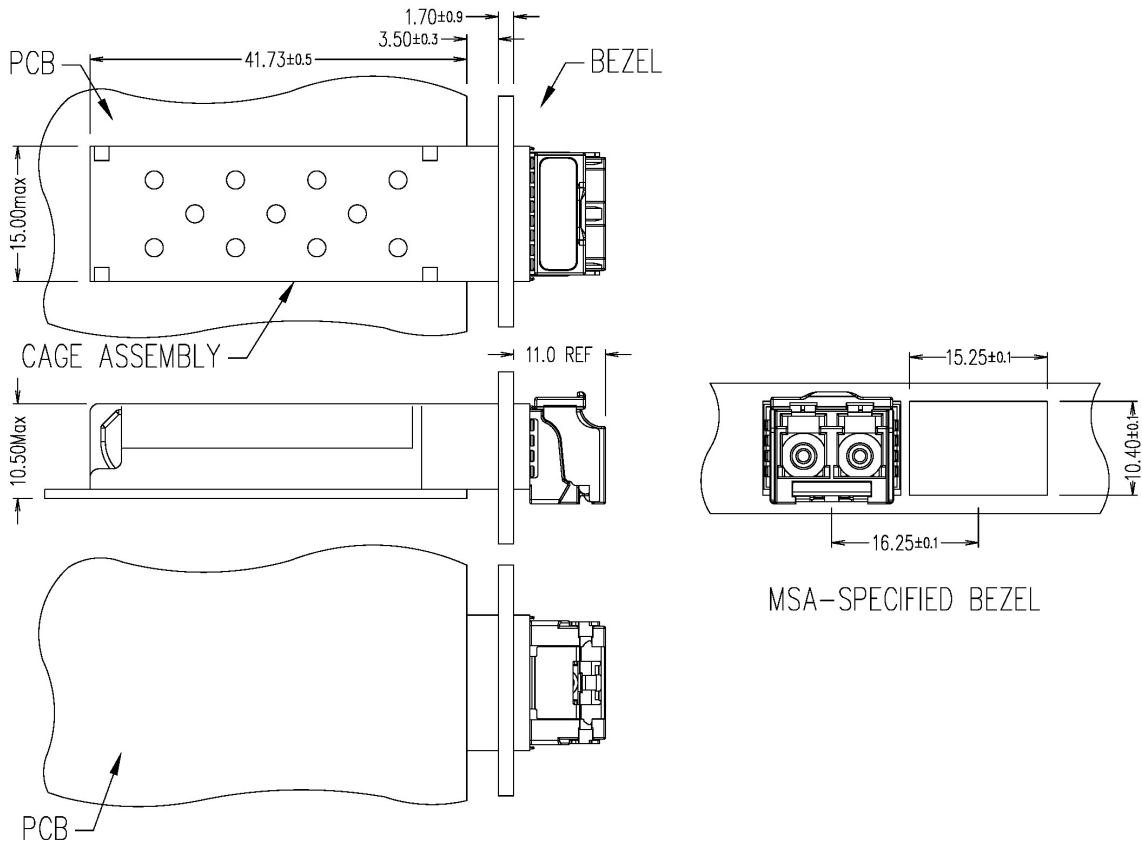

Eye Safety

The transceiver is a class 1 laser product. It complies with EN60825-1:2014/A11:2021 and FDA 21 CFR 1040.10 and 1040.11. In order to meet laser safety requirements, the transceiver shall be operated within the Absolute Maximum Ratings.

Caution

All adjustments have been done at the factory before the shipment of the devices. No maintenance and user serviceable part is required. Tampering with and modifying the performance of the device will result in voided product warranty.

