

ARGUS® F200

B A S I C F I B E R T E S T E R

Sel. OPM

xPON-ID

Through Mode

GPON

XGS-PON

FTTH

PON Installation

FIT

OLTS

VFL

WLAN

Data
101101011011

iperf

RFC
6349



data sheet: technical data subject to change.

FIBER TESTERS
MADE IN GERMANY

intec
GESELLSCHAFT FÜR
INFORMATIONSTECHNIK mbH

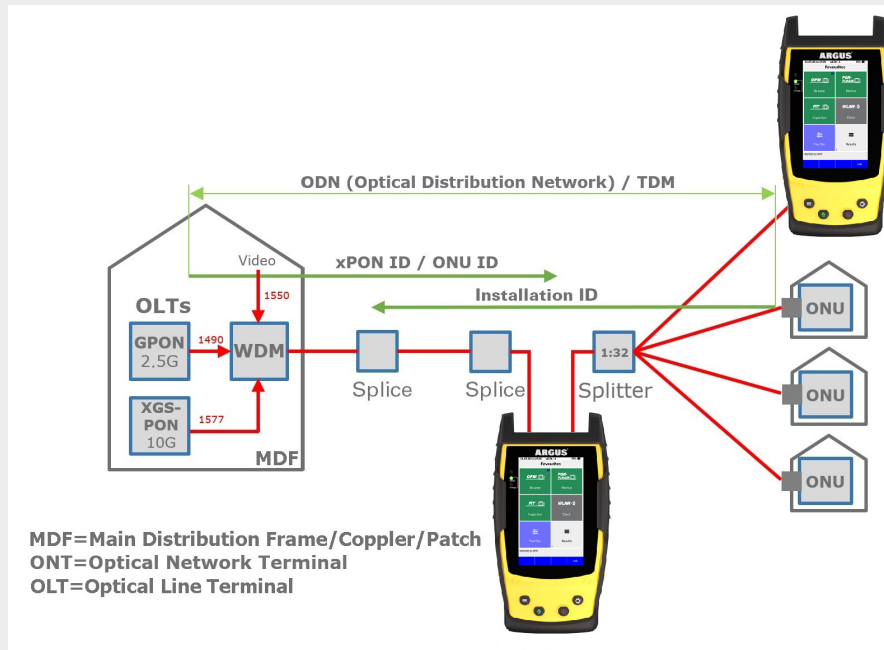

ARGUS® F200: The basic fiber tester

The ARGUS® F200 is a specialized selective power meter, designed for use in GPON and XGS-PON networks.

Modern design and new housing concept

With its robust and even more compact design than its predecessors, the ARGUS® F200 is ideally suited to the demands of daily field service use. The device is equipped with a user-friendly touchscreen and the familiar intuitive ARGUS® menu navigation. Thanks to the freely configurable favorites feature, the most frequently used functions can be accessed even more quickly.

Tests on mixed optical fiber accesses

The ARGUS® F200 supports measurements at three or optionally four or five wavelengths. The selective 4-fold powermeter can be switched into an existing PON connection in through mode, enabling the optical levels on the different downstream (OLT) and upstream (ONT) wavelengths for GPON and XGS-PON to be determined precisely at the same time. Other transmitters that may be on the line (so-called Alien-ONT) can be detected. In addition, the PON ID can be read out from the PLOAM message. A PLOAM monitor scans all ONU IDs and serial numbers of connected ONTs on a PON branch. With the 5xOPM, a video overlay via five separate filters is also possible as an option.

Additional features

The ARGUS® F200 also features 2.4GHz wireless technology and WLAN management. In addition, the Fiber Inspection Tool can be connected via USB, which detects scratches and defects on optical fibers and displays them as a video image and in tabular form.

intec Gesellschaft für Informationstechnik mbH

For over 35 years, intec Gesellschaft für Informationstechnik mbH has stood for innovative measurement technology - developed and produced for telecommunications networks in Europe. Our ARGUS® testers make fiber optic and broadband infrastructures accessible, document efficiently and support daily maintenance and troubleshooting in fiber optic and copper networks as well as via Ethernet. We deliver what network operators and service technicians need: speed, security and trust.

Our solutions are optimally adapted to European standards, norms and protocols. Linguistic and technical localization, fast shipping within the EU and direct technician support guarantee short distances and fast help without detours. For us, "Made in Europe" stands for quality, transparency and sustainability. Thanks to modular, scalable products, we serve both small companies and large network operators. Long-term product maintenance and regular updates make your investment future-proof.

We are driven by our innovation: We integrate the latest technologies such as GPON, XGS-PON, ADSL2+, VDSL2 vectoring, VDSL2 bonding, VDSL2 profile 35b or G.fast (profile 106a and 212a) and are constantly developing our portfolio. This means that ARGUS® testers are ideally equipped for current and future requirements. Our user interface is based on freely configurable tiles: technicians start directly with the appropriate measurement configuration - simple, fast and error-free. Clearly displayed results are transmitted via WLAN to smartphones, central servers or the ARGUS® app. Supervisors can also take over devices remotely and provide active support. Central management and archiving of test results make it easier to handle large network structures - significantly reducing training costs and error rates.

Our ARGUS® testers have been sold over 100,000 times - including to leading European network operators such as Deutsche Telekom, Vodafone, Telefónica, KPN, BT and Telekom Austria.

data sheet: technical data subject to change.

Specifications Fiber Tests:

General:		Application, Settings + Results:	
Selective xPON-OPM for GPON / XGS-PON 3xOPM	<ul style="list-style-type: none"> Measuring range: <ul style="list-style-type: none"> 1577 & 1490 nm (filtered): from -40 to +6 dBm (max. power +18 dBm) 1270, 1300, 1310, 1550, 1610, 1625 nm (broadband): from -50 to +13 dBm (max. power +18 dBm) 	<ul style="list-style-type: none"> Accuracy: ±0.5 dB Calibration conditions: -20 dBm, 23°C ±5 K Connector: SC/APC 	<ul style="list-style-type: none"> Readout of PON ID and XGS-PON ID* via SC/APC, detection up to: <ul style="list-style-type: none"> GPON ≥ -31 dBm XGS-PON ≥ -30 dBm <p>* The network must provide the ID for this.</p>
Selective Through Mode xPON-OPM for GPON/ XGS-PON 4XOPM opt. 5xOPM	<ul style="list-style-type: none"> Measuring range: <ul style="list-style-type: none"> Downstream (OLT socket): <ul style="list-style-type: none"> 1577 & 1490 nm (filtered): from -40 to +9 dBm (max. power +18 dBm) Upstream (ONT socket): <ul style="list-style-type: none"> 1310 & 1270 nm (filtered): from -35 to +10 dBm (max. power +18 dBm) opt. 1550 nm (filtered): from -40 to +16 dBm Accuracy: filtered ±0.5 dB 	<ul style="list-style-type: none"> Insertion loss: 1.5 dB Alien ONT detection (burst + permanent) Calibration conditions: -20 dBm, 23°C ±5 K Connector: 2x SC/APC (ONT + OLT) Readout of PON ID and XGS-PON ID* via SC/APC, detection up to: <ul style="list-style-type: none"> GPON ≥ -28 dBm XGS-PON ≥ -27 dBm 	<ul style="list-style-type: none"> Remote control of the OLS with switching of the wavelengths and transmission of the transmission power via TWIN mode (only in conjunction with OLS) <p>* The network must provide the ID for this.</p>
PLOAM Monitor	(Physical Layer Operation Administration and Maintenance) <ul style="list-style-type: none"> Scan of PLOAM messages Message trace with timestamp 	<ul style="list-style-type: none"> PLOAM sniffer directly on the fiber via PON socket (no replugging) for GPON and XGS-PON 	<ul style="list-style-type: none"> Resync counter Display of: <ul style="list-style-type: none"> ONU ID ONT serial number

External enhancements:

General:		Application, Settings + Results:	
Fiber Inspection Tool ext. Video Microscope	<ul style="list-style-type: none"> USB Microscope for the ARGUS optical Fiber Inspection manual Focusing with separate key optional: Autofocus digital Zoom 	<ul style="list-style-type: none"> Pass /Fail evaluation according to IEC 61300-3-35 min. Particle Size 0.5 µm Defects: Core, Cladding, Adhesive, Contact 	<ul style="list-style-type: none"> Scratches: Core, Cladding, Adhesive, Contact different Tips /Adapters included in scope of delivery PC, UPC, APC Single Mode /Multi Mode
VFL ext. Visual Fault Locator	<ul style="list-style-type: none"> Mini Visual Laser Source Output Power: 1 mW Detecting Range: about 5 km 	<ul style="list-style-type: none"> Wavelength: 650 nm Laser Level: Class 2 Connector: Un/FC 	<ul style="list-style-type: none"> Modulation Frequency: CW / 2 Hz Power Supply: 2 * AAA batteries
OLS ext. Optical Light Source	<ul style="list-style-type: none"> Wavelength: 1310 nm, 1490 nm, 1550 nm +1625 nm (± 20 nm) Stability: <ul style="list-style-type: none"> Short term (15 min): <ul style="list-style-type: none"> 1310 nm < ±0,05 dB 1490 nm < ±0,10 dB 1550 nm < ±0,05 dB 1625 nm < ±0,10 dB Long term (5 h): <ul style="list-style-type: none"> 1310 nm < ±0,10 dB 1490 nm < ±0,20 dB 1550 nm < ±0,10 dB 1625 nm < ±0,20 dB 	<ul style="list-style-type: none"> Connector: SC/APC with dust protection and protection against loss Spectral width: 5 nm Frequency: 270 Hz, 1 KHz, 2 KHz Power: -5 dBm ±0.5 dB Auto power off / backlight 	<ul style="list-style-type: none"> Power supply: 2x Ni-MH AA (2500 mAh), AC/DC charger Dimension (L x W x H): 160 x 76 x 45 mm Net weight: 270 g Accessories: AC/DC charger, 2 x AA battery ARGUS® can be enhanced with an Optical Loss Test Set (separate option)

data sheet: technical data subject to change.

Specifications Protocol and IP tests:

General:	Applications, Settings + Results:	
Protocol Tests	<ul style="list-style-type: none"> Configurable MAC Address Configurable in Profiles (20) <ul style="list-style-type: none"> - IP, PPPoE - VLAN (Modus, ID, Prio., TPID) - PPP Profiles (Username, Password) - IP Version (IPv4, IPv6, Dual) + DHCP - Automatic receiving of connection-dependent dial-in data: PPP, VoIP (phone number) 	<ul style="list-style-type: none"> Display of BRAS Information <ul style="list-style-type: none"> - AC Name, Service Name, Session ID Display of PPP Information <ul style="list-style-type: none"> - PPP Packets/Bytes (Tx/Rx) - PPP Trace (PPP Commands, Time) Display of IP Information <ul style="list-style-type: none"> - IPv6: Global Unicast/Link Local Address - IPv4: Assigned IP, Gateway, DNS
Data Tests (Download Tester)	<ul style="list-style-type: none"> Memory with up to 10 IP Addresses, (IPv4/6 Address as Number or Name) Number of Pings, Pause Configurable (Ping), Packet Size + Fragmentation Configurable Traceroute: Max. Hops, Probes + Timeout Conf. Down-/Upload: Server Profiles (10): Server Addr., File Name/Size, Number, Number of Parallel Downloads Configurable <ul style="list-style-type: none"> - FTP: Username + Password Display Results IP Ping <ul style="list-style-type: none"> - Display of Packets (Tx/Rx/repeated) - Checksum Error [Number] - Error Packets [Number] Display Results Traceroute <ul style="list-style-type: none"> - Current Hop + Probe / List of Hops - Response Time of Hops [s] - IP Address of Current Hops 	<ul style="list-style-type: none"> Round Trip Time (min/max/avg) [ms] Display Results Down- /Upload <ul style="list-style-type: none"> - Current/Total Number [Number] - Already Loaded Data [%] - Average Speed [Mbit/s] - Loaded Bytes [MB] - Transfer Time /Remaining Time [h:min:s] ARGUS® Real Speed Direct (iperf) <ul style="list-style-type: none"> - Speedtests - Client /Server Mode - TCP Throughput Down- /Upload - ARGUS® against ARGUS® ARGUS® Real Speed Formal (RFC6349) <ul style="list-style-type: none"> - Throughput Test - Evaluation TCP Throughput according to RFC 6349
IP Ping Test		
Traceroute Test		
HTTP Up-/Download Test		
FTP Up-/Download Test		
FTP Server Test		
ARGUS® Real Speed Formal (RFC6349)		
ARGUS® Real Speed Direct (iperf)		

Further specifications:

General:	Application, Settings + Results:	
WLAN Management	<ul style="list-style-type: none"> WLAN Access Point Scan <ul style="list-style-type: none"> - Number / List Access Points - Number 2.4 GHz Networks - Network/Name (SSID) - Signal Strength (RSSI) [dBm] - Signal Quality - Authentication 	<ul style="list-style-type: none"> AP Management (save etc.) Test Result Upload via Web Server, WebDAV and FTP Configuration Download via WebDAV and FTP Remote Control via VNC, Web Server <ul style="list-style-type: none"> - Firmware Update via FTP Download

data sheet: technical data subject to change.

Documentation and Analysis

- **Documentation** of all parameters recorded to test reports (in device and on PC) via automatic access tests
- Transfer of test results via **QR code** to a smartphone or via **WLAN** to cloud (FTP server)
- Transfer of measurement results to the **ARGUS® Mobile App**
- Free of charge firmware updates via **cloud** or via **USB** (www.argus.info)
- **WLAN** for transf. test results to systems of an electronic order processing system, access point mode, remote control via smartphone (see above)

Device Specifications

Technical Features:

- | | |
|-----------------------------|--|
| • Power | Li-Ion battery pack or plug-in mains adapter |
| • Power management | User configurable |
| • Keypad | 4 keys |
| • TFT colour display | 800 x 480 pixels, backlit, incl. touchscreen |
| • 2 LEDs | Indicating the status |
| • ARGUSpedia | Integrated help function |
| • CE marking | Complies with CE directives |
| • User safety | Fulfills EN 62368-1 |
| • RoHS conformance | Conformance according to WEEE directive |

Interfaces:

- | | |
|-------------------------|--|
| • 1x SFP+ Port | for GPON and XGS-PON transceivers |
| • USB interfaces | 1x USB 2.0 host type A, 1x USB 2.0 client type C |
| • WLAN | IEEE802.11b/g/n/ac, ax detection |
| • Bluetooth | |

Environmental conditions:

- | | |
|---|--|
| • Temperature range for charging battery pack | 0 °C (+32 °F) up to +40 °C (+104 °F) |
| • Max. Operating temperature (endurance tests) | 0 °C (+32 °F) up to +40 °C (+104 °F) |
| • Max. Operating temperature (in battery mode) | -10 °C (+14 °F) up to +50 °C (+122 °F) |
| • Operating temperature (with power/car adapter) | 0 °C (+32 °F) up to +40 °C (+104 °F) |
| • Storing Temperature | -20 °C (-4 °F) up to +60 °C (+140 °F) |
| • Relative humidity | Up to 95 %, non-condensing |

Dimensions:

- | | |
|-----------------|---|
| • Size | H x W x D: 225 x 120 x 68mm (8.85 x 4.72 x 2.68 in) |
| • Weight | approx. 815 g (1.80 lbs) ARGUS incl. battery pack |

data sheet: technical data subject to change.

Standard Package:		
Basic device incl. Selective xPON OPM, PON ID, WLAN management, 2.4GHz wireless technology, Li-Ion battery pack, mains adaptor, shock absorbing rubber jacket, carrying case, SC/APC measuring cable		
Basic packages:		
• 3xOPM		Order number: 120602
• 4xOPM incl. Through Mode + Up-/Downstream measurement		Order number: 120632
• 5xOPM incl. Through Mode + Up-/Downstream measurement		Order number: 120612
Additional Options:		
• ONT simulation	sets the SW options GPON and/or XGS-PON-ONT simulation; incl. IP ping, traceroute, FTP/HTTP up/download	Order number: 020601
• GPON transceiver	requires Art. No. 020601	Order number: 020602
• XGS-PON transceiver	requires Art. No. 020601	Order number: 020603
• Optical Light Source (1310, 1490, 1550, 1625 nm)	external	Order number: 000280
• Optical Light Source (1310, 1550 nm)	external	Order number: 000297
• Optical Loss Test inkl. 2λOLS	SW-Option Optical Loss Test & 2λOLS: 1310 & 1550 nm	Order number: 020061
• Optical Loss Test inkl. 4λOLS	SW-Option Optical Loss Test & 4λOLS: 1310, 1490, 1550, 1625 nm	Order number: 020062
• Visual Fault Locator(VFL)	external	Order number: 000281
• Fiber Inspection option	w/o Fiber Inspection Tool	Order number: 020694
• ARGUS® Real Speed Formal (6349)	incl. ARGUS® Real Speed Direct (iperf)	Order number: 020656
• ARGUS® Real Speed Direct (iperf)	Client/ Server	Order number: 020668
* We would be glad to provide further details and information about additional accessories on request.		

