

# ARGUS® F240

T H E F I B E R T E S T E R

Sel. OPM

xPON-ID

Through Mode

GPON

XGS-PON

FTTH

PON installation

FIT

OLTS

VFL

2.5GigE

10GigE

SFP

WLAN

Data

IP TV

Vo IP

Speed test

iperf

RFC 6349



data sheet: technical data subject to change.

FIBER TESTERS  
MADE IN GERMANY

**intec**  
GESELLSCHAFT FÜR  
INFORMATIONSTECHNIK mbH

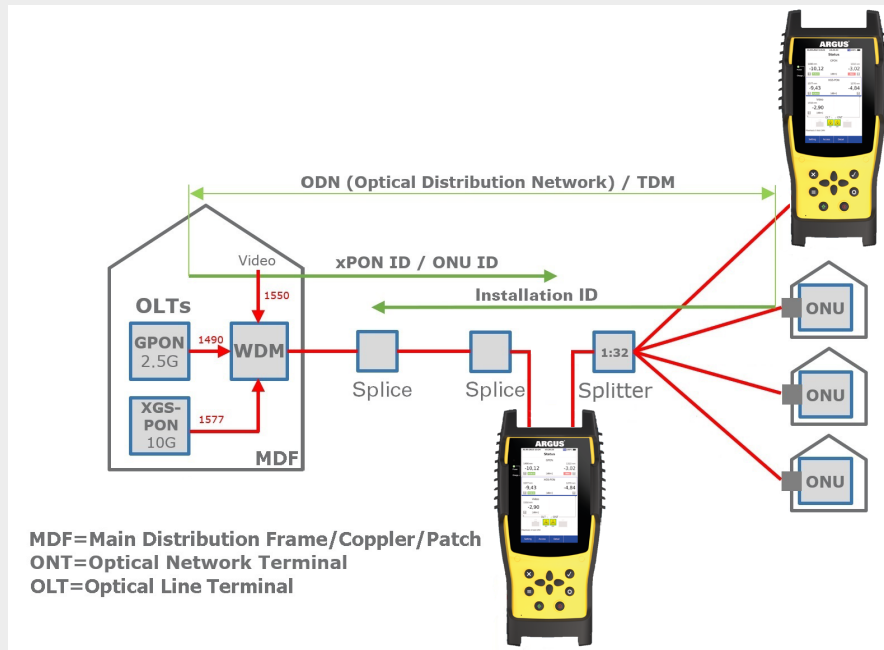

## ARGUS® F240: The fiber tester

The ARGUS® F240 fiber tester scores with improved performance when testing on mixed fiber optic connections. The high-quality tester is well equipped for the expansion of future networks.

## Modern design and new housing concept

With its robust and compact design, the ARGUS® F240 is ideally suited for the demands of daily field use. It is operated primarily via touchscreen, with familiar ARGUS® menu structure.

## Tests on mixed optical fiber accesses

The ARGUS® F240 reliably tests on GPON and XGS-PON interfaces in the quality you have come to expect. The selective 4-fold power meter can be switched into an existing PON connection in through mode, allowing the optical levels on the different downstream (OLT) and upstream (ONT) wavelengths for GPON and XGS-PON to be determined precisely at the same time. In this process, other transmitters that may be on the line (so-called alien ONT) can be detected. In addition, the PON ID can be read out from the PLOAM message. A PLOAM monitor scans all ONU IDs and serial numbers of connected ONTs on a PON branch. With the 5xOPM, a video overlay via five separate filters is also possible as an option. On GPON as on XGS-PON, the ARGUS® can also perform a complete ONT simulation with IP and performance tests at up to 10 Gbit/s.

## Additional features

The ARGUS® F240 also has many other test functions, such as WLAN analyzer, triple play tests such as VoIP, IPTV and data tests in the form of upload/download, ping and traceroute as well as iperf or high-performance IP speed tests directly on the fiber or on Ethernet. The SFP slot can be used, among other things, for the deployment of Active Ethernet (AON), as is often the case in FTTH installations. In addition, the Fiber Inspection Tool can be connected via USB, which detects scratches and defects on optical fibers and displays them as a video image and in tabular form.

## intec Gesellschaft für Informationstechnik mbH

For over 35 years, intec Gesellschaft für Informationstechnik mbH has stood for innovative measurement technology - developed and produced for telecommunications networks in Europe. Our ARGUS® testers make fiber optic and broadband infrastructures accessible, document efficiently and support daily maintenance and troubleshooting in fiber optic and copper networks as well as via Ethernet. We deliver what network operators and service technicians need: speed, security and trust.

Our solutions are optimally adapted to European standards, norms and protocols. Linguistic and technical localization, fast shipping within the EU and direct technician support guarantee short distances and fast help without detours. For us, "Made in Europe" stands for quality, transparency and sustainability. Thanks to modular, scalable products, we serve both small companies and large network operators. Long-term product maintenance and regular updates make your investment future-proof.

We are driven by our innovation: We integrate the latest technologies such as GPON, XGS-PON, ADSL2+, VDSL2 vectoring, VDSL2 bonding, VDSL2 profile 35b or G.fast (profile 106a and 212a) and are constantly developing our portfolio. This means that ARGUS® testers are ideally equipped for current and future requirements. Our user interface is based on freely configurable tiles: technicians start directly with the appropriate measurement configuration - simple, fast and error-free. Clearly displayed results are transmitted via WLAN to smartphones, central servers or the ARGUS® app. Supervisors can also take over devices remotely and provide active support. Central management and archiving of test results make it easier to handle large network structures - significantly reducing training costs and error rates.

Our ARGUS® testers have been sold over 100,000 times - including to leading European network operators such as Deutsche Telekom, Vodafone, Telefónica, KPN, BT and Telekom Austria.

Specifications Fiber Tests:

General: Application, Settings + Results:			
<b>Selective xPON-OPM</b> for GPON / XGS-PON 3xOPM	<ul style="list-style-type: none"> <li>Measuring range:                             <ul style="list-style-type: none"> <li>1577 &amp; 1490 nm (filtered): from -40 to +6 dBm (max. power +18 dBm)</li> <li>1270, 1300, 1310, 1550, 1610, 1625 nm (broadband): from -50 to +13 dBm (max. power +18 dBm)</li> </ul> </li> <li>Accuracy: ±0.5 dB</li> <li>Calibration conditions: -20 dBm, 23°C ±5 K</li> </ul>	<ul style="list-style-type: none"> <li>Connector: SC/APC, SFP+, LAN 10 GBase-T</li> <li>Readout of PON ID and XGS-PON ID* via SC/APC, detection up to:                             <ul style="list-style-type: none"> <li>GPON ≥ -29 dBm</li> <li>XGS-PON ≥ -30 dBm</li> </ul> </li> <li>Full ONT simulation (GPON ONT or XGS-PON ONT) via additional GPON/ XGS-PON SFP transceiver module</li> </ul>	<ul style="list-style-type: none"> <li>IP/Performance tests via SFP+, LAN4 10/5/2.5/1 GBase-T, 100Base-Tx with up to 1 Gbit/s (max. 2.5 Gbit/s)</li> <li>Remote control of the OLS with switching of the wavelengths and transmission of the transmission power via TWIN mode (only in conjunction with OLS)</li> </ul> <p>* The network must provide the ID for this.</p>
<b>Selective Through Mode xPON-OPM</b> for GPON/ XGS-PON 4xOPM opt. 5xOPM	<ul style="list-style-type: none"> <li>Measuring range:                             <ul style="list-style-type: none"> <li>Downstream (OLT socket):                                     <ul style="list-style-type: none"> <li>1577 &amp; 1490 nm (filtered): from -40 to +9 dBm (max. power +18 dBm)</li> </ul> </li> <li>Upstream (ONT socket):                                     <ul style="list-style-type: none"> <li>1310 &amp; 1270 nm (filtered): from -35 to +10 dBm (max. power +18 dBm)</li> </ul> </li> <li>opt. 1550 nm (filtered): from -40 to +16 dBm</li> </ul> </li> <li>Accuracy: filtered ±0.5 dB</li> </ul>	<ul style="list-style-type: none"> <li>Insertion loss: 1.5 dB</li> <li>Alien ONT detection (burst + permanent)</li> <li>Calibration conditions: -20 dBm, 23°C ±5 K</li> <li>Connector: 2x SC/APC (ONT + OLT), SFP+, LAN 10 GBase-T</li> <li>Full ONT simulation (GPON ONT or XGS-PON ONT) via additional GPON/ XGS-PON SFP transceiver module</li> </ul>	<ul style="list-style-type: none"> <li>Readout of PON ID and XGS-PON ID* via SC/APC, detection up to:                             <ul style="list-style-type: none"> <li>GPON ≥ -30 dBm</li> <li>XGS-PON ≥ -29 dBm</li> </ul> </li> <li>IP/Performance tests via SFP+, LAN 10/5/2.5/1 GBase-T, 100Base-Tx with up to 10 Gbit/s (opt.)</li> </ul> <p>* The network must provide the ID for this.</p>
<b>GPON Tester</b>	GPON Modem Simulation, ONT, CPE ITU-T G.984 via GPON Transceiver <ul style="list-style-type: none"> <li>GigaBit Passive Optical Network</li> </ul> DDM accord. to SFF-8472 (see Ethernet)	<ul style="list-style-type: none"> <li>Link Status / Link Speed</li> <li>ONT Status / OLT Tx Power</li> <li>Optical Network Unit ID (ONU ID)</li> <li>Passive Optical Network ID (PON ID, Vendor + Equipment ID / Version)</li> <li>GPON Bridge/Router*</li> </ul>	<ul style="list-style-type: none"> <li>GPON Status Trace</li> <li>Serial Number / Password Configurable</li> <li>Scan PLOAM message (ONU ID, S/N)*</li> <li>SFP: Digital Diagnostic Mode (DDM)</li> <li>Optical Level (Rx), ±3 dB</li> <li>Optical Line Attenuation in dB</li> </ul>
<b>XGS-PON Tester</b>	XGS-PON Modem Simulation, ONT, CPE ITU-T G.9807.1 via XGS-PON Transceiver <ul style="list-style-type: none"> <li>10 GigaBit Symmetric Passive Optical Network</li> </ul> DDM accord. to SFF-8472 (see Ethernet)	<ul style="list-style-type: none"> <li>Link Status / Link Speed</li> <li>ONT Status / OLT Tx Power</li> <li>Optical Network Unit ID (ONU ID)</li> <li>Passive Optical Network ID (PON ID, Vendor + Equipment ID / Version)</li> <li>XGS-PON Bridge/Router*</li> </ul>	<ul style="list-style-type: none"> <li>XGS-PON Status Trace</li> <li>Serial Number / Password Configurable</li> <li>Scan PLOAM message (ONU ID, S/N)*</li> <li>SFP: Digital Diagnostic Mode (DDM)</li> <li>Optical Level (Rx), ±3 dB</li> <li>Optical Line Attenuation in dB</li> </ul>
<b>PLOAM-Monitor</b>	(Physical Layer Operation Administration and Maintenance) <ul style="list-style-type: none"> <li>Scan of PLOAM messages</li> <li>Message trace with timestamp</li> </ul>	<ul style="list-style-type: none"> <li>PLOAM sniffer directly on the fiber via PON socket (no replugging)</li> <li>for GPON and XGS-PON</li> </ul>	<ul style="list-style-type: none"> <li>Resync counter</li> <li>Display of:                             <ul style="list-style-type: none"> <li>ONU ID</li> <li>ONT serial number</li> </ul> </li> </ul>

data sheet: technical data subject to change.

External extensions:

General: Application, Settings + Results:			
<b>Fiber Inspection Tool</b> ext. Video Microscope	<ul style="list-style-type: none"> <li>• USB Microscope for the ARGUS</li> <li>• optical Fiber Inspection</li> <li>• manual Focusing with separate key</li> <li>• optional: Autofocus</li> <li>• digital Zoom</li> </ul>	<ul style="list-style-type: none"> <li>• Pass /Fail evaluation according to IEC 61300-3-35</li> <li>• min. Particle Size 0.5 µm</li> <li>• Defects: Core, Cladding, Adhesive, Contact</li> </ul>	<ul style="list-style-type: none"> <li>• Scratches: Core, Cladding, Adhesive, Contact</li> <li>• different Tips /Adapters included in scope of delivery</li> <li>• PC, UPC, APC</li> <li>• Single Mode /Multi Mode</li> </ul>
<b>VFL</b> ext. Visual Fault Locator	<ul style="list-style-type: none"> <li>• Mini Visual Laser Source</li> <li>• Output Power: 1 mW</li> <li>• Detecting Range: about 5 km</li> </ul>	<ul style="list-style-type: none"> <li>• Wavelength: 650 nm</li> <li>• Laser Level: Class 2</li> <li>• Connector: Un/FC</li> </ul>	<ul style="list-style-type: none"> <li>• Modulation Frequency: CW / 2 Hz</li> <li>• Power Supply: 2 * AAA batteries</li> </ul>
<b>OLS</b> ext. Optical Light Source	<ul style="list-style-type: none"> <li>• Wavelength: 1310 nm, 1490 nm, 1550 nm +1625 nm (± 20 nm)</li> <li>• Stability:                             <ul style="list-style-type: none"> <li>- Short term (15 min): 1310 nm &lt; ±0,05 dB 1490 nm &lt; ±0,10 dB 1550 nm &lt; ±0,05 dB 1625 nm &lt; ±0,10 dB</li> <li>- Long term (5 h): 1310 nm &lt; ±0,10 dB 1490 nm &lt; ±0,20 dB 1550 nm &lt; ±0,10 dB 1625 nm &lt; ±0,20 dB</li> </ul> </li> </ul>	<ul style="list-style-type: none"> <li>• Connector: SC/APC with dust protection and protection against loss</li> <li>• Spectral width: 5 nm</li> <li>• Frequency: 270 Hz, 1 KHz, 2 KHz</li> <li>• Auto wavelength: protocol-based wavelength and TX power transmission</li> <li>• Power: -5 dBm ±0.5 dB</li> <li>• Auto power off / backlight</li> </ul>	<ul style="list-style-type: none"> <li>• Power supply: 2x Ni-MH AA (2500 mAh), AC/DC charger</li> <li>• Dimension (L x W x H): 160 x 76 x 45 mm</li> <li>• Net weight: 270 g</li> <li>• Accessories: AC/DC charger, 2 x AA battery</li> <li>• ARGUS® can be enhanced with an Optical Loss Test Set (separate option)</li> </ul>

data sheet: technical data subject to change.

Further specifications:

General:		Application, Settings + Results:	
<b>GigE Tester</b>	<p>Ethernet according to IEEE 802.3</p> <p>LAN:</p> <p>RJ45 interface (8P8C)</p> <ul style="list-style-type: none"> <li>• 10/100/1000 Base-T</li> <li>• 2.5 GBase-T (IEEE 802.3bz, NBase-T)</li> <li>• 5/10 GBASE-T (5/10 GbE), 5000/10000 BASE-T, (MGBASE-T) (IEEE 802.3ak, IEEE 802.3an)</li> </ul> <p>SFP: full-fledged SFP+ interface (FTTx, PtP)</p> <ul style="list-style-type: none"> <li>• 1000 Base-BX/LX/SX/ZX Active Ethernet (IEEE 802.3 Clause 38 bzw. 802.3z)</li> <li>• 2,5 GBase-X (2,5GigE/2,5GbE)</li> </ul> <p>10 GBASE-X (10GbE/10GE), 10000 BASE-X (IEEE 802.3ae)</p>	<ul style="list-style-type: none"> <li>• Link Status, Autonegotiation, far/near</li> <li>• Auto-MDI(X) Function</li> <li>• Speed (10, 100, 1000, 2500, 10000 Mbit/s)</li> <li>• Duplex Mode (full, half)</li> <li>• Flow Control</li> <li>• Polarity/Wire Pair (+/-)</li> <li>• Pair skew/Wire Pair [ns]</li> <li>• Frames (Rx/Tx) [Number]</li> <li>• Errors, Bytes (Rx/Tx) [Number]</li> <li>• Collisions [Number]</li> </ul>	<ul style="list-style-type: none"> <li>• SFP: Digital Diagnostic Mode (DDM)                             <ul style="list-style-type: none"> <li>- DDM nach SFF-8472</li> <li>- Manufacturer Name, OUI, Item Number, Revision</li> <li>- Serial Number, Date, Coding, Medium, Speed</li> <li>- Optical Level (Tx/Rx), ±3 dB</li> <li>- Optical, PWR (Tx/Rx), ±3 dB</li> <li>- Temperature, Voltage, Current (Tx)</li> <li>- Max. Cable Length (Cu,SM,MM/OM1-4)</li> </ul> </li> </ul>
<b>WLAN</b>	<p>WLAN Access Point Mode</p> <p>WLAN Client Mode</p> <ul style="list-style-type: none"> <li>• via int. opt. interface                             <ul style="list-style-type: none"> <li>- Tri-Band (2.4; 5 and 6 GHz), 2x2</li> <li>- WiFi7 (IEEE802.11 a/b/g/n/ac/ax/be)</li> </ul> </li> <li>• via ext. USB stick, max.                             <ul style="list-style-type: none"> <li>- Dual-Band (2.4 and 5 GHz), 2x2</li> <li>- WiFi5 (IEEE802.11 a/b/g/n/ac)</li> <li>- WiFi6e (IEEE802.11 a/b/g/n/ac/ax)</li> <li>- WiFi6/7 detection (IEEE802.11 ax/be)</li> <li>- WPA2/WPA3 Personal/Enterprise, OWE</li> </ul> </li> </ul>	<ul style="list-style-type: none"> <li>• WLAN Access Point Scan                             <ul style="list-style-type: none"> <li>- Number / List Access Points</li> <li>- Number 2.4 GHz / 5 GHz Networks</li> <li>- Network/Name (SSID)</li> <li>- Signal Strength (RSSI) [dBm]</li> <li>- Signal Quality [%]</li> <li>- MAC Address of AP</li> <li>- Used Channel/Frequency</li> <li>- Used Protocol</li> <li>- Negotiated Encryption</li> <li>- Authentication</li> <li>- Group Cipher, Pairwise Cipher</li> </ul> </li> </ul>	<ul style="list-style-type: none"> <li>• Access Point Mode (WLAN Router) for mobile devices</li> <li>- IP Tests (Data, VoIP, IPTV)</li> <li>• AP Management (save etc.)</li> <li>• Test Result Upload via Web Server, WebDAV and FTP</li> <li>• Configuration Download via WebDAV and FTP</li> <li>• Remote Control via VNC, Web Server</li> <li>- Firmware Update via FTP Download</li> </ul>
<b>ARGUS® WLAN Analyzer</b>	<ul style="list-style-type: none"> <li>• Displaying the networks during existing WLAN connection</li> <li>• Manual evaluation of channels possible in tabular and graphical form</li> </ul>	<ul style="list-style-type: none"> <li>• Searching for networks again during existing WLAN connection</li> </ul>	<ul style="list-style-type: none"> <li>• Advanced automated evaluation of found networks and display of all AP info</li> </ul>
<b>WLAN spectrum analysis</b>	<ul style="list-style-type: none"> <li>• optional: ext. ARGUS® 2G4 Scope graph. WLAN spectrum analysis for 2.4 GHz for the specific WLAN troubleshooting</li> </ul>	<ul style="list-style-type: none"> <li>• Real-time Analysis/Graphics</li> <li>• passive (no WLAN Interference)</li> <li>• Channel Load</li> <li>• Graphical representation</li> </ul>	<ul style="list-style-type: none"> <li>• Detection of                             <ul style="list-style-type: none"> <li>- Bluetooth Devices</li> <li>- Motion Sensors</li> <li>- Microwave Ovens</li> <li>- Baby Phones</li> </ul> </li> </ul>

data sheet: technical data subject to change.

## Specifications Protocol and IP tests (Triple Play)

General:	Applications, Settings + Results:	
<b>Protocol Tests</b>	<ul style="list-style-type: none"> <li>Configurable MAC Address</li> <li>Use of Virtual Lines (VL): Maximum Flexibility as well as Control and Priorization under Real Conditions by Several VLs simultaneously</li> <li>One VL/Service each (Data, VoIP, IPTV, opt.)</li> <li>VL Configurable in Profiles (20)                             <ul style="list-style-type: none"> <li>IP, PPPoE</li> <li>VLAN (Modus, ID, Prio., TPID)</li> <li>PPP Profiles (Username, Password)</li> <li>IP Version (IPv4, IPv6, Dual) + DHCP</li> <li>Automatic receiving of connection-dependent dial-in data: PPP, VoIP (phone number)</li> </ul> </li> </ul>	<ul style="list-style-type: none"> <li>Display of BRAS Information                             <ul style="list-style-type: none"> <li>AC Name, Service Name, Session ID</li> </ul> </li> <li>Display of PPP Information                             <ul style="list-style-type: none"> <li>PPP Packets/Bytes (Tx/Rx)</li> <li>PPP Trace (PPP Commands, Time)</li> </ul> </li> <li>Display of IP Information                             <ul style="list-style-type: none"> <li>IPv6: Global Unicast/Link Local Address</li> <li>IPv4: Assigned IP, Gateway, DNS</li> </ul> </li> <li>Recording of a Data Log for Evaluation on PC (e.g. Wireshark)</li> </ul>
<b>Data Tests (Download Tester)</b> PC/Terminal Simulation IP Ping Test Traceroute Test HTTP Up-/Download Test FTP Up-/Download Test FTP Server Test Webbrowser ARGUS® Real Speed Formal (RFC6349) ARGUS® Real Speed Direct (iperf)	<ul style="list-style-type: none"> <li>Memory with up to 10 IP Addresses, (IPv4/6 Address as Number or Name)</li> <li>Number of Pings, Pause Configurable (Ping), Packet Size + Fragmentation Configurable</li> <li>Traceroute: Max. Hops, Probes + Timeout Conf.</li> <li>Down-/Upload: Server Profiles (10): Server Addr., File Name/Size, Number, Number of Parallel Downloads Configurable                             <ul style="list-style-type: none"> <li>FTP: Username + Password</li> </ul> </li> <li>Display Results IP Ping                             <ul style="list-style-type: none"> <li>Display of Packets (Tx/Rx/repeated)</li> <li>Checksum Error [Number]</li> <li>Error Packets [Number]</li> </ul> </li> <li>Round Trip Time (min/max/avg) [ms]</li> </ul>	<ul style="list-style-type: none"> <li>Display Results Traceroute                             <ul style="list-style-type: none"> <li>Current Hop + Probe / List of Hops</li> <li>Response Time of Hops [s]</li> <li>IP Address of Current Hops</li> </ul> </li> <li>Display Results Down- /Upload                             <ul style="list-style-type: none"> <li>Current/Total Number [Number]</li> <li>Already Loaded Data [%]</li> <li>Average Speed [Mbit/s]</li> <li>Loaded Bytes [MB]</li> <li>Transfer Time /Remaining Time [h:min:s]</li> </ul> </li> <li>ARGUS® Real Speed Direct (iperf)                             <ul style="list-style-type: none"> <li>Speedtests up to 10 Gbit/s, depending on utilization (min. 1 Gbit/s guaranteed)</li> <li>Client /Server Mode</li> <li>TCP Throughput Down- /Upload</li> <li>ARGUS® against ARGUS®</li> </ul> </li> <li>ARGUS® Real Speed Formal (RFC6349) Throughput Test                             <ul style="list-style-type: none"> <li>Evaluation TCP Throughput according to RFC 6349</li> </ul> </li> </ul>
<b>VoIP Tests (VoIP Tester)</b> IP Telephone Simulation Testing of VoIP Connections incl. Acoustics (dif. Codecs) MOS Evaluation (ITU-T P.800) Call Generator (up to 30 Calls)	<ul style="list-style-type: none"> <li>Configuration in VoIP Profiles (20): SIP Username, Password, Registrar Server, Out-bound Proxy/SBC, Domain, Listen + Remote Port, Authentication, Caller ID, User Agent, Qualify, Process of Registration</li> <li>Phone Settings: RTP Port Area, Silence Detection, Jitterbuffer, Codecs, DTMF</li> <li>STUN Server</li> <li>MOS Threshold for OK/Fail Evaluation</li> <li>VoIP QoS, Layer 3 Diffserv: RTP/SIP: ToS, DSCP</li> <li>VoIP QoS, Layer 2 VLAN Prio.: RTP/SIP: VLAN Prio.</li> <li>Codecs: G.726 (16/24/32/40), G.729 (A/B), G.711 (a-law/μ-law), G.722</li> <li>Display of Own Number, Number of Called Person</li> </ul>	<ul style="list-style-type: none"> <li>Duration of Connection [h:min:s]</li> <li>MOS Plain Text Evaluation, According to E Model R Factor, ITU-T G. 107 (current/avg), MOS (current/avg/min/max/ideal)</li> <li>Statistics: RTP Packets (Tx/Rx),</li> <li>Error Counter: RTP Drop, RTP Error</li> <li>RTP Jitter Rx (current/avg/min/max)</li> <li>Lost RTP Packets (avg/min/max)</li> <li>RTCP Contents:                             <ul style="list-style-type: none"> <li>RTP Jitter far (current/avg/min/max) [ms]</li> <li>Lost RTP Packets of Remote Side</li> <li>Network Delay (current/avg/min/max) [ms]</li> <li>Display of Registration Details: SIP Codes, Registrar IP, Proxy, URI</li> </ul> </li> <li>Simulation (VoIP NT)</li> </ul>

data sheet: technical data subject to change.

General:	Applications, Settings + Results:	
<b>IPTV Tests (IPTV Tester)</b> IPTV Device Simulation IPTV STB Simulation (Set-top Box) OK/Fail Evaluation IPTV Channel Scan IPTV Monitor (IPTV passive)	<ul style="list-style-type: none"> <li>• Configuration in IPTV Profiles (3): Editable Channel List (up to 250 Channels), Multicast IP + Port, Channel Name, IGMP version</li> <li>• Thresholds for IPTV OK/Fail-Evaluation: IGMP Latency, Sync Error, PCR Jitter, Error Indication, CC Errors, CC Error Rate, Audio + Video Bytes, RTP Jitter, RTP Sequence Error, Current + Total RTP Loss Rate</li> <li>• Different VLs for IGMP + RTP</li> <li>• Scan Profiles (3) Configurable: max. Zapping Time</li> <li>• Display of Selected IPTV Channel, Test Duration, current Bitrate, OK or Fail</li> <li>• Packets Loss (current/min/max/avg) [Number]</li> </ul>	<ul style="list-style-type: none"> <li>• RTP/UDP Packet Loss Rate [%]</li> <li>• Delay [ms] + Delay Factor [ms]</li> <li>• Media Loss Rate (MLR) [%]</li> <li>• IP Address of Channel + Port</li> <li>• IGMP Latency (Activation Time) [ms]</li> <li>• For Correlation: xDSL CRC Counters</li> <li>• RTP Errors, RTP Sequence Errors</li> <li>• MPEG Bitrate + Packets (min/max/...), Bytes (current/min/max/...), PCR Jitter (current/min/max/avg) [ms], CC Errors + Error Rate (current/max) [%], Error Sync + Indication</li> <li>• Codecs and PIDs (Packet Identifier)</li> <li>• Channel Zapping Time (min/max/avg) [ms]</li> </ul>

Documentation and Analysis
<ul style="list-style-type: none"> <li>• <b>Documentation</b> of all parameters recorded to test reports (in device and on PC) via automatic access tests</li> </ul>
<ul style="list-style-type: none"> <li>• Transfer of test results via <b>QR code</b> to a smartphone or via <b>WLAN</b> to cloud (FTP server)</li> </ul>
<ul style="list-style-type: none"> <li>• Transfer of measurement results to the <b>ARGUS® Mobile App</b></li> </ul>
<ul style="list-style-type: none"> <li>• Free of charge firmware updates via <b>cloud</b> or <b>ARGUS update tool</b> (<a href="http://www.argus.info">www.argus.info</a>)</li> </ul>
<ul style="list-style-type: none"> <li>• <b>WLAN</b> for transf. test results to systems of an electronic order processing system, access point mode (browsing, download), remote control via smartphone</li> </ul>

data sheet: technical data subject to change.

Device Specifications	
<b>Technical Features:</b>	
• Power	Li-Ion battery pack or plug-in mains adapter
• Power management	User configurable
• Keypad	8 keys, 4 cursor keys
• TFT colour display	800 x 480 pixels, backlit, incl. touchscreen
• 3 LEDs	Indicating the status + Ethernet port LEDs
• Handset	Integrated earpiece and microphone
• ARGUSpedia	Integrated help function
• CE marking	Complies with CE directives
• User safety	Fulfills EN 62368-1
• RoHS conformance	Conformance according to WEEE directive
<b>Interfaces:</b>	
• 1x Ethernet	10/100/1000 Base-T, 2,5 GBase-T, 5 GBase-T, 10000 Base-T/10 GigE
• 1x SFP+ Port	1000 Base-SX/LX/ZX/BX, 2,5 GBase-X, 10 GBase-X/10 GigE
• USB interfaces	2x USB 2.0 host type A, 1x USB 2.0 client type C
• WLAN	IEEE802.11a/b/g/n/ac, ax recognition
<b>Environmental conditions:</b>	
• Temperature range for charging battery pack	0 °C (+32 °F) up to +40 °C (+104 °F)
• Max. Operating temperature (endurance tests)	0 °C (+32 °F) up to +40 °C (+104 °F)
• Max. Operating temperature (in battery mode)	-10 °C (+14 °F) up to +50 °C (+122 °F)
• Operating temperature (with power/car adapter)	0 °C (+32 °F) up to +40 °C (+104 °F)
• Storing Temperature	-20 °C (-4 °F) up to +60 °C (+140 °F)
• Relative humidity	Up to 95 %, non-condensing
<b>Dimensions:</b>	
• Size	H x W x D: 272 x 128 x 79 mm (10.71 x 5.04 x 3.11 in)
• Weight	approx. 1200 g (2.65 lbs) ARGUS incl. battery pack

data sheet: technical data subject to change.

Standard Package:		
Basic device incl. Selective xPON OPM, PON ID, Wi-Fi-Management, IP tests (IP ping, traceroute test, HTTP/FTP download, FTP upload/server), Web browser, Cloud services, Lithium-Ion battery pack, Mains adaptor, Shock absorbing rubber jacket, Carrying case, SC/APC measuring cable, Carrying strap, Hand strap and English manual		
Additional Options:		
• PON installation test	w/o stick	Order number: 024610
• GPON-ONT for xPON-OPM	incl. GPON Transceiver SFP	Order number: 024602
• XGS-PON-ONT for xPON-OPM	incl. XGS-PON Transceiver SFP	Order number: 024603
• xPON 4x OPM	incl. Through Mode + Up/Downstream level measurement	Order number: 024608
• xPON 5x OPM	incl. Through Mode + Up/Downstream level measurement	Order number: 024604
• Visual Fault Locator (VFL)	external	Order number: 000281
• Optical Light Source (1310, 1490, 1550, 1625 nm)	external	Order number: 000280
• Optical Light Source (1310, 1550 nm)	external	Order number: 000297
• Optical Loss Test inkl. 2λOLS	SW-Option Optical Loss Test & 2λOLS: 1310 & 1550 nm	Order number: 020061
• Optical Loss Test inkl. 4λOLS	SW-Option Optical Loss Test & 4λOLS: 1310, 1490, 1550, 1625 nm	Order number: 020062
• Fiber Inspection option	w/o Fiber Inspection Tool	Order number: 024694
• Wi-Fi Test Interface	w/o Wi-Fi USB stick, see accessories price list*	Order number: 024659
• Wi-Fi7 module	requires Art.No. 024659, 024654 and 024606	Order number: 024620
• ARGUS® WLAN Analyzer	requires Art.No. 024659	Order number: 024654
• ARGUS® 2G4 Scope (2.4 GHz Spectrum Analysis)	incl. USB 2G4 Scope stick	Order number: 000240
• VoIP Option	incl. MOS value, Call generator, NT Sim., SIP trunk	Order number: 024660
• IPTV Option	incl. IPTV STB mode, IPTV passive, channel scan	Order number: 024665
• Triple Play package	incl. VoIP and IPTV Option	Order number: 024667
• ARGUS® Real Speed Formal (6349)	incl. ARGUS® Real Speed Direct (iperf), requires Art. No. 024605	Order number: 024656
• Speedtest up to 2.5 Gbit/s	via Ethernet (LAN4, SFP4), Wi-Fi + fiber via transceiver SFP incl. ARGUS® Real Speed Direct (iperf); requires Art. No. 024604	Order number: 024605
• Speedtest up to 10 Gbit/s	via Ethernet (LAN4, SFP4), Wi-Fi + fiber via transceiver SFP incl. ARGUS® Real Speed Direct (iperf); incl. Ethernet Cat6 Patch Cable 1:1 (red); requires Art. No. 024604	Order number: 024606
* We would be glad to provide further details and information about additional accessories on request.		

