



Remote Spectrum Monitor

High-Performance RF Spectrum Monitor

MS27201A

9 kHz to 9/14/20/26.5/32/43.5/54 GHz



Remote Spectrum Monitor MS27201A

OVERVIEW

Demand for access to the RF spectrum continues to grow at an increasing pace. Alongside new cellular bands, the use of RF spectrum by satellite operators, microwave links, radar, and defense electronics expands each year.

Efficient and effective use of the spectrum by users requires a deep insight into the total radio frequency activity by other users in region. The Remote Spectrum Monitor MS27201A is designed to facilitate wide area spectrum monitoring up to 9 kHz to 54 GHz. Building on over 40 years of experience in developing high performance field portable spectrum analyzers, the Remote Spectrum Monitor MS27201A series is our highest frequency spectrum monitor covering all standard LMR, cellular, satellite, and defense electronic bands.



Remote Spectrum Monitor MS27201A is Available with 9 kHz to 54 GHz Frequency Range Options

Key Specifications

Parameter	Specification
Frequency Range	9/14/20/26.5/32/43.5/54 GHz
Analysis Bandwidth	150 MHz
Third Order Intercept Point (TOI)	+20 dBm
DANL (with pre amp)	-164 dBm
Amplitude Range	DANL to +30 dBm
Phase Noise @ 1 GHz	-110 dBc/Hz @ 100 kHz offset (typical)
RBW/VBW	1 Hz to 10 MHz
Amplitude Accuracy	< 14 GHz ± 1.3 dB (± 0.5 dB typical)
RTSA Bandwidth	150 MHz (option dependent)

Key Features

Feature	Specification
Control Interfaces	Ethernet
PC Control	Anritsu Remote and Report Tools (ARRT)
Automated Monitoring Software	MX280001A Vision monitor PC application
IQ	Capture and streaming IQ data through Ethernet, USB, and PCIe interfaces
Channel Scanner	Horizontal bar chart, strip chart and mapping mode with channels up to 60
Cellular Measurements	WCDMA, 5G NR FR1, and LTE FDD/TDD transmitter measurement suites
Continuous Operation and Recovery	Built in watchdog timer and auto recover on power failure provide continuity of service
Traces	Six with independent detectors per trace
Markers and Limits	12 Intelligent markers and comprehensive limits
Event Capture	Save traces and alarms on defined events

Remote Spectrum Monitor MS27201A

Designed for Long Term Monitoring Applications

Compact Rack Mount Format

The Remote Spectrum Monitor MS27201A instruments are standard 19-inch rack wide and 2U tall. They are designed to slot directly into test system racks using minimal space. The instruments are powered from a supplied 75 Watt power block that minimizes rack temperature gain.

High Performance

Typical applications for the Remote Spectrum Monitor MS27201A requires excellent noise floor for signal detection and high TOI to minimize internal distortions when the input is exposed to multiple input signals. With a displayed average noise level (DANL) of -164 dBm and a TOI of typically $+20$ dBm, signal detection, and measurement integrity are assured. Measurement bandwidths of up to 110 MHz with IQ capture and streaming options provide class leading functionality in a small form factor package.

24/7 Operation

The Remote Spectrum Monitor MS27201A is designed for continuous operation. Recovery features are included to ensure reliable and uninterrupted monitoring. A built-in watchdog timer resets the instrument in the event of a software interruption. Should a break in the power supply occur, when the power is restored the instrument will resume normal operation in the same state it was in prior to loss of power.

IQ Capture and Streaming

The Remote Spectrum Monitor MS27201A provides for the capture of IQ data of Signals-of-Interest (SOI) for later post processing. When an illicit signal is detected, post capture analysis is performed to identify the source of the signal. The 150 MHz (per Option 105) measurement bandwidth enables the captures of transient and continuous signals to internal instrument memory or directly to a mass storage device. Dedicated PCI interfaces provide the bandwidth required for the most demanding cases where real-time streaming is required.

Optional vector signal analysis software MX280005A performs modulation analysis on common digital modulation standards for greater insights.



PCIe Streaming Kit

WCDMA, LTE and 5G NR Modulation Quality Measurements

Options for WCDMA, LTE and 5G demodulations enables detailed analysis of these common cellular standards. Measurements including base station PCI and bandwidth as well as frequency to facilitate the identification of rogue or illicit transmitters. Coupled with the spectrogram and IQ capture, field technicians have an array of tools to capture and analyze signals in the cellular spectrum.

Distributed Spectrum Monitors with Centralized Control

Connect multiple Remote Spectrum Monitor MS27201A instruments to a network and control them from a single centralized PC.

Remote Spectrum Monitor MS27201A

WCDMA FDD Base Station Measurements (Option 871)

Network operators with legacy 3GPP WCDMA networks continue to need field maintenance instruments. The WCDMA base station measurement option includes the essential measurements required for base station maintenance. This provides field engineers a single test instrument that supports the most common technologies in a network. WCDMA measurements supported include:

- Occupied Bandwidth
- Spectral Emission Mask
- Channel Power
- Adjacent Channel Power
- Carrier Frequency
- Frequency Error
- Scrambling Code
- Common Pilot Channel Power (CPICH)
- Primary Synchronization Channel Power (P-SCH)
- Secondary Synchronous Channel Power (S-SCH)
- Primary Common Control Physical Channel (P-CCPCH)
- EVM on P-CPICH Pilot Channel

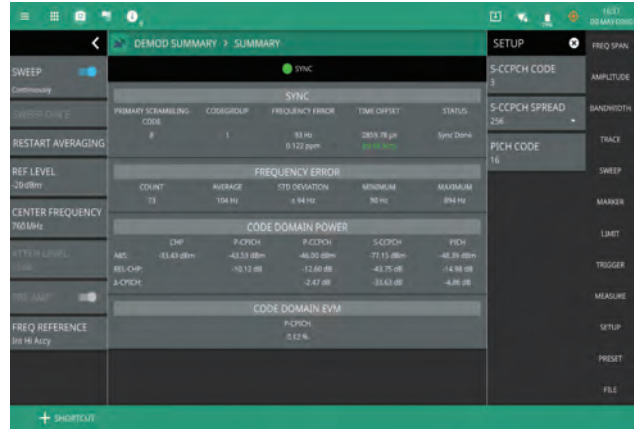

WCDMA Modulation Analysis Summary Screen

The Anritsu Remote and Report Tools (ARRT) is able to switch seamlessly between the control of multiple Remote Spectrum Monitor MS27201A instruments. When monitoring the RF spectrum across a wide area, a single PC can configure and control multiple instruments to simplify the operation.

When using MX280001A Vision software, the spectrum traces from multiple Remote Spectrum Monitor MS27201A instruments are displayed on the PC screen providing a quick and clear overview of all activity in the area under surveillance.

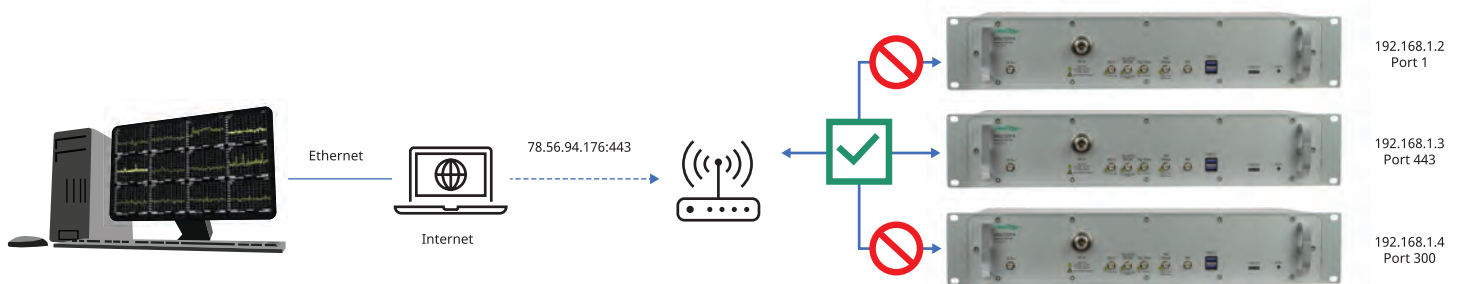

A Single PC can Control Multiple MS27201As on a Common Network

Rich in Features to Enhance Spectrum Monitoring

The Remote Spectrum Monitor MS27201A is packed with all the features required to perform long term spectrum monitoring. In addition to six simultaneous traces, each of which can be configured with a different detector, the Remote Spectrum Monitor MS27201A offers:

- Built-in RTSA (150 MHz) with 2.05 μ s POI provides the ultimate signal analysis and interference capture tool
- 12 intelligent markers for labeling and identifying signals
- Limit lines with multiple segments and automatic set up around active signals
- Save on events including time interval and mask violation
- Smart measurements to rapidly characterize signals OBW, Channel Power, and spectral emission
- Spectrogram display with time stamps for historic recording
- Record and playback of trace data for analysis of intermittent signals

Remote Spectrum Monitor MS27201A



Common Spectrum Analyzer Measurements including Channel Power are Automated with Smart Measurements

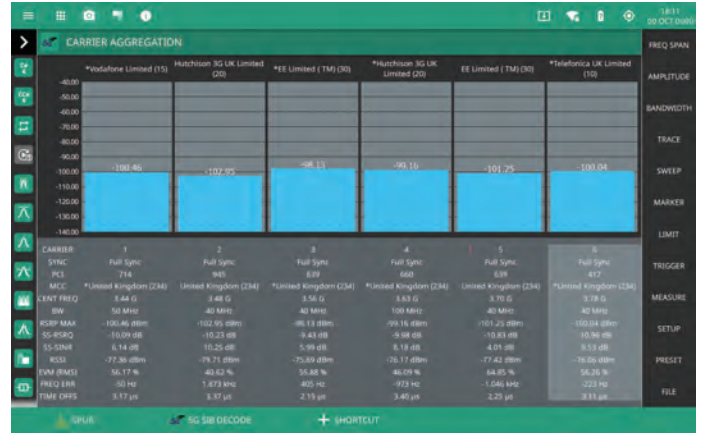

Modulation Measurement Options Perform Modulation Analysis on LTE and 5G Base Station Wave Signals



AM/FM Modulation Measurement Option Delivers the Most Comprehensive Measurement Suite in a Remote Spectrum Analyzer. The RF Spectrum, Audio Frequency Spectrum, Demodulated Audio in the Time Domain (oscilloscope format), and Numeric Results for Key Parameters are all Displayed on the Remote Software Screen

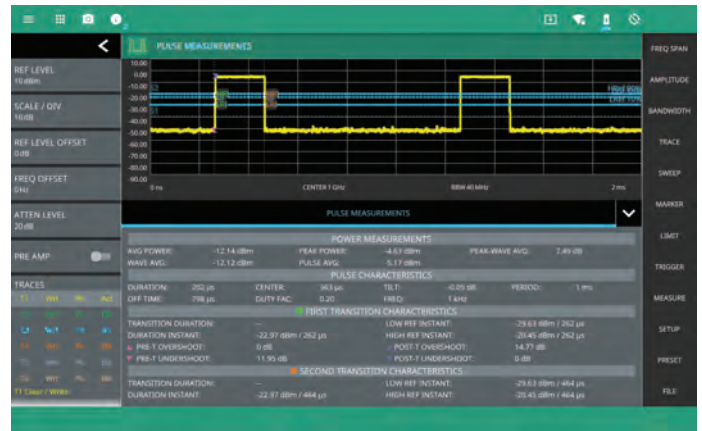

The MS27201A Pulse Analyzer Option Automates the Capture and Display of Pulsed Signals, Providing a Comprehensive Readout of All Standard Measurements

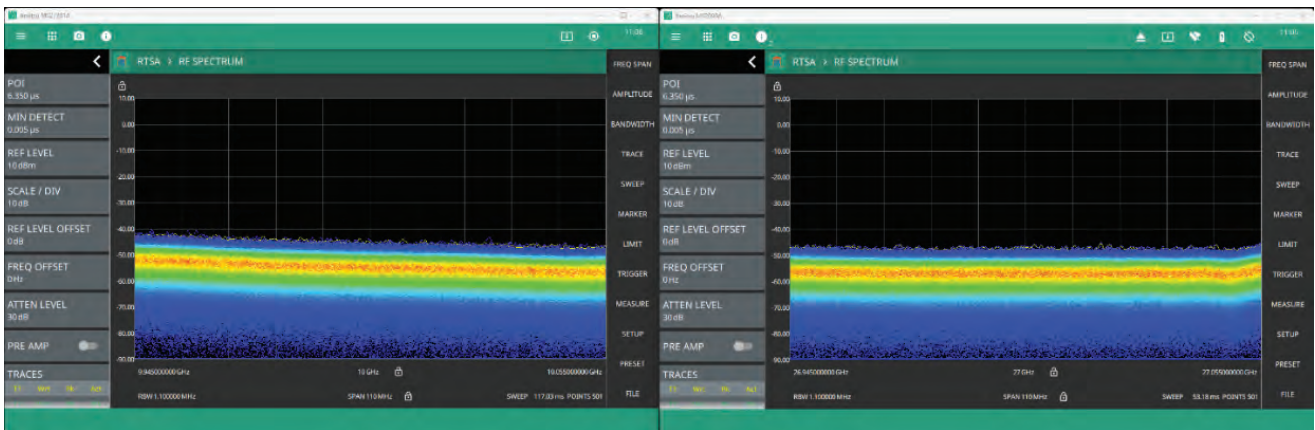

With Real-Time Spectrum Analysis (RTSA), Interference and Pulse Signals that Would be Undetectable in Traditional Sweep can be Observed with the Remote GUI. The Remote GUI Allows the Control of Multiple Instruments with RTSA Simultaneously. Great for Looking for Identifying Intermittent Signals

Remote Spectrum Monitor MS27201A

APPLICATIONS

Spectrum Clearing

Frequency spectrum is typically allocated and policed by a national regulator. Licenses for specific blocks of spectrum are time limited and can change their use as new technologies and applications evolve. When a new license is issued, the new spectrum owner needs to survey the spectrum to confirm legacy users have ceased transmitting. As transmitters may only be active periodically, monitoring the spectrum for a period of days or weeks may be necessary to ensure all legacy users have moved out of the spectrum.

The Vision software option has integrated tools to simplify this spectrum clearing process.

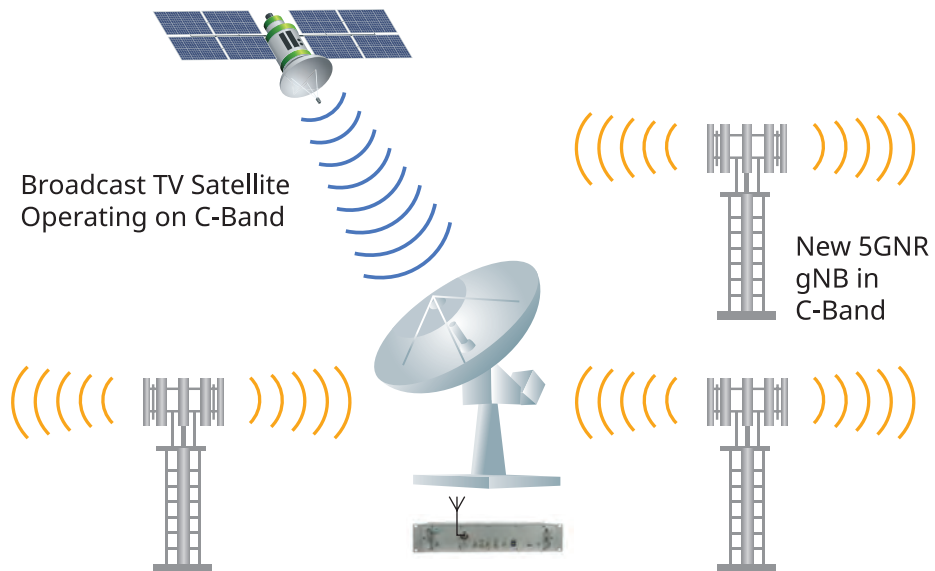

MS27201A Monitoring for Adjacent Channel Interference from New Cellular Base Stations with Legacy Satellite Downlinks

Remote Spectrum Monitor MS27201A

APPLICATIONS *(Continued)*

Shared Spectrum Monitoring

It is becoming increasingly common for more than one technology to be allocated access to the same block of spectrum. Early examples of spectrum sharing is the 3.5 GHz band in the USA where legacy military radars and new commercial cellular networks share the same spectrum. A tiered access regulation manages their co-existence. In order for operators to understand how this will affect their long term ability to provide a service, they need to continuously monitor activity in the spectrum to build up a understanding of likely availability over days and months.

The Remote Spectrum Monitor MS27201A with MX280001A Vision software or custom monitoring applications enables spectrum owners to build up maps of how the spectrum is being used and what access they can expect, depending on their status in any tiered system.

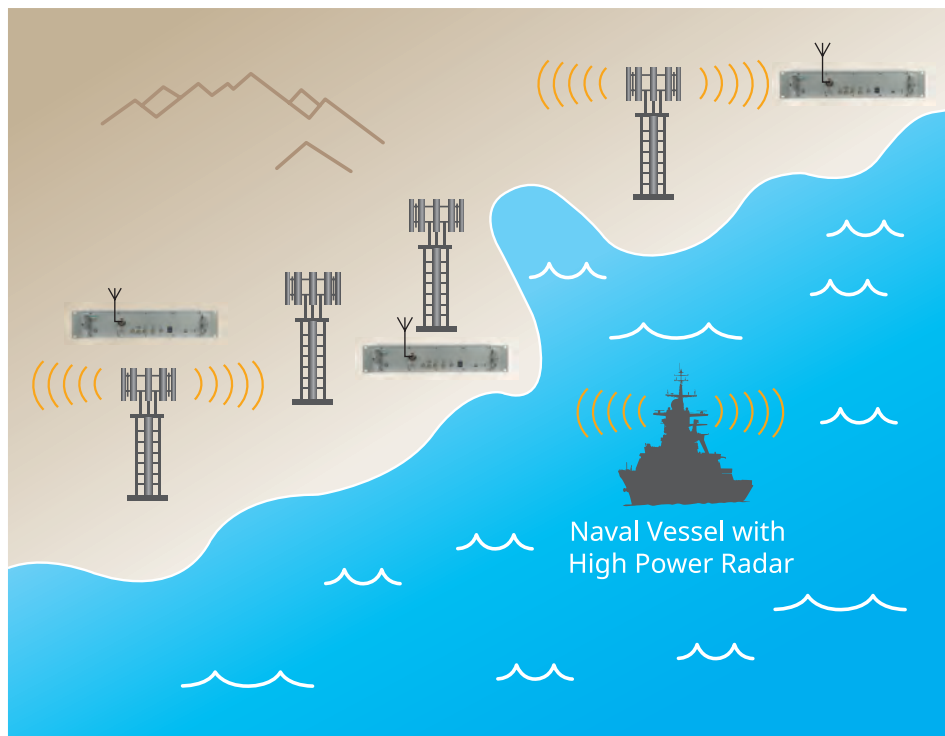

Military Radar and Commercial Communications Systems often Share the Same Spectrum with Priority Access

Remote Spectrum Monitor MS27201A

APPLICATIONS *(Continued)*

Satellite Ground Station Monitoring

The expansion of satellite services is growing rapidly. Satellites have become ubiquitous providers of communications systems and monitoring of multiple properties of the earth, including weather, light pollution, and heat sources. The proliferation of low earth orbit communications networks and GNSS positioning system has resulted in forecast of thousands of satellites orbiting the earth.

Satellite downlink signals typically arrive at the surface of the earth with very low signal level and the latest generation of satellites are starting to use millimeter-wave (mmWave) frequencies for these downlinks, including 8 to 9 GHz X band for space research, 12 GHz Ku band for domestic TV broadcast and 23 to 27 GHz for fixed link broadcasts.

The sensitivity of satellite downlink receivers make them very susceptible to interfering signals. Continuous monitoring of the in-band and adjacent frequencies is essential to maintain robust communications and understand if and when additional filtering may be required.

At earth stations with multiple dishes, Remote Spectrum Monitor MS27201A instruments can be located at the base of the dish to monitor activity across the site in real time. A single monitor showing the spectrum at each receiver provides a dashboard that alerts operators of potential interference, giving the earliest possible warning of potential communications failure.

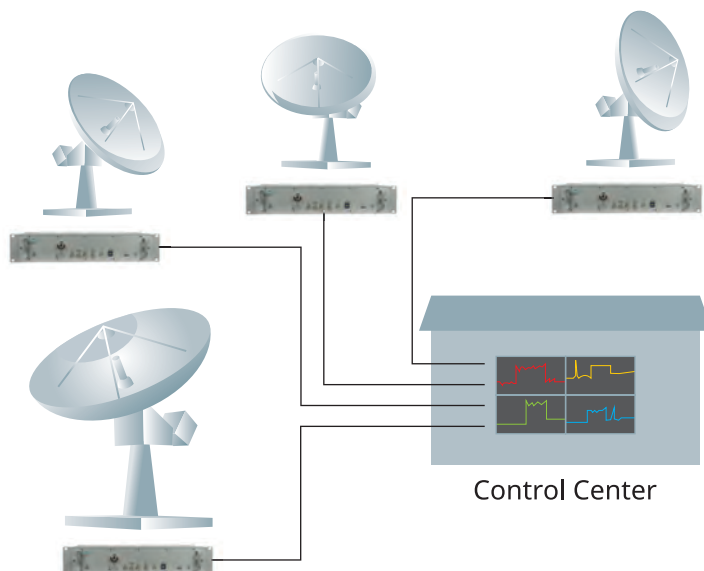

*Monitor the Downlink Spectrum from Multiple Ground Stations
with a Single PC in the Control Room*

Remote Spectrum Monitor MS27201A

APPLICATIONS *(Continued)*

Critical Site Security

Many government defense and commercial sites have experienced aggressive and intentional interference from hostile agents. On-site communications are critical for the smooth running of large sites with many interdependent automated systems. Monitoring and early detection of hostile transmissions is essential to effective site operation. Examples of vulnerable sites include classified buildings, transport hubs and government offices.

Positioning MS27201A spectrum monitors across a site with broadband spectrum coverage gives the best possible security against such attacks. The measurements from all deployed instruments are routed back to a common control room facilitating monitoring and rapid detection of interfering signals at any location across a site.

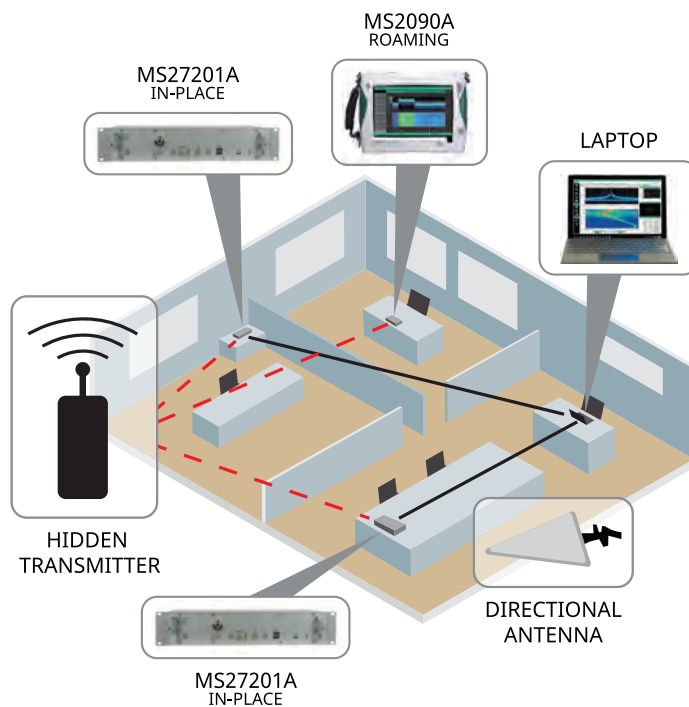

Combination of RSM and HH SPA to Help Identify Hidden Transmitters

Interference Monitoring

Major sporting events, festivals, and conferences bring together multiple agencies to a single location for maybe only a few days or weeks. Each contributing agency often has unique communications and telematics requirements that require temporary licensing. Typical examples include international motor racing events, football tournaments, and global music festivals. To ensure all the stakeholders' systems are transmitting on their approved frequencies and not interfering requires strict monitoring of the spectrum.

Remote spectrum monitoring MS27201A instruments cover all the frequency allocations that are active at such events such as telematics links, radio microphones, satellite news gathering, and broadcast point-to-point radio links.

Regulatory Enforcement

National regulators need to police spectrum activity in large urban areas. Large cities will have multiple licensed transmitters and unless the spectrum is policed, there will be interference and degraded performance across all systems.

Remote Spectrum Monitor MS27201A

INSTRUMENT CONTROL OPTIONS *(Continued)*

The Remote Spectrum Monitor MS27201A can be controlled using customer written PC Anritsu Remote and Report Tools (ARRT), a downloadable PC Graphical User Interface (GUI), or with the MX280001A Vision Monitor PC software application.

Remote Spectrum Monitor MS27201A PC Anritsu Remote and Report Tools (ARRT)

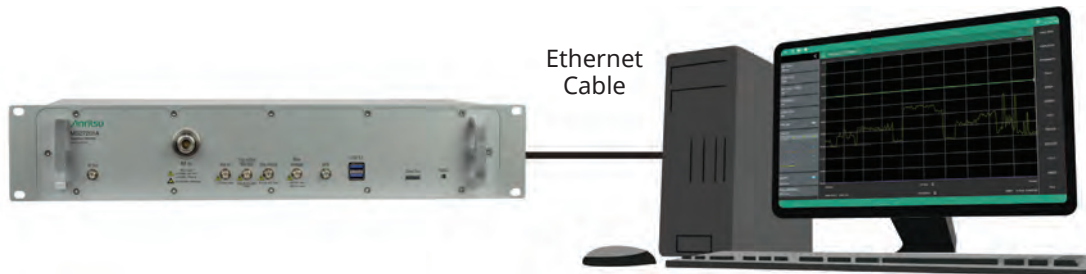

The MS27201A PC ARRT Software Provides an Off-the-Shelf GUI for Common Applications

A downloadable PC application provides a comprehensive user interface. Connect to any Remote Spectrum Monitor MS27201A on the same network to take manual control of the instrument, configure measurements, and save results. No special user training is required as the PC GUI is based on the standard Anritsu spectrum analyzer interface. Traces and IQ data are stored directly to the PC memory for ease of later recall and playback functionality. Full screen captures can be saved as well as individual result traces, traces saved by “Save on Event” triggers or traces continuously saved over a defined period of time.

The Remote Spectrum Monitor MS27201A instrument’s ARRT Software is ideal for manual configuration and viewing of spectrums when continuous monitoring is not required. All the standard features of a spectrum analyzer are available to capture specific events and save images or trace files directly to the PC memory. Manual real-time configuration of the spectrum monitor allows targeted configurations for detailed signal analysis and investigation.

Remote Spectrum Monitor MS27201A

INSTRUMENT CONTROL OPTIONS *(Continued)*

Remote Spectrum Monitor MX280001A Vision Monitor Software Application



View the Spectrum Traces from Multiple MS27201A on a Single PC Monitor with the Vision High-Speed Port Scanner Option

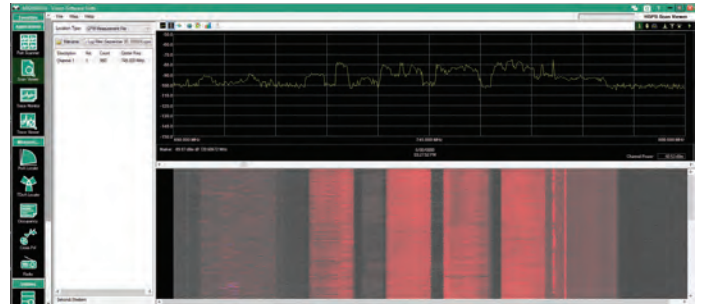

Log Spectrum Traces for Extended Time Periods and Monitor for Interfering Signals with Alarms and Alerts

When long-term monitoring is required, the optional Vision software offers a full suite of spectrum monitoring and trace archiving options.

Vision Monitor software offers a range of applications for monitoring the RF spectrum over a period of time and storing results to a database. Vision Monitor is an ideal tool for long-term interference monitoring. Limits can be set with automated alarms for limit violations to capture short-term or intermittent signals. Other features include a scanner option that enables the monitoring of a range of frequency bands or channels over time with unique settings for each channel being monitored. A multi-trace view shows the spectrum for all channels being monitored on the same display.

The Vision Monitor application is fully automated. Measurements can be captured and periodically uploaded to a database for further processing. Depending on need and storage capacity, users can store spectrum history over many months or years with a user-defined capture assigned schedule.

All spectrum measurement databases are searchable, allowing the user to quickly locate patterns of signal activity relevant to an investigation. The spectrum history can also potentially be used in legal proceedings for documenting illegal or unlicensed broadcast activity. Other functions provided by Vision Monitor include:

- Threshold and trace mask settings for alarm generation
- Email alert sent when threshold violation generates an alarm
- Reporting on spectrum integrity on a daily or weekly basis
- Vision runs on a PC/laptop using the Windows® operating system (Windows 10/11)
- Option 401 (enable Vision Locate)

Real-Time Spectrum Analyzer (Option 199)

For many spectrum and network stakeholders, basic spectrum sweeps may not give enough information. The RTSA option provides real-time signal capture with 150 MHz bandwidth and the ability to capture signals down to a 2.05 μ s duration with 100% POI at full amplitude. This provides unrivaled insight into interference in the wireless spectrum, capturing interfering signals that are too short in duration to be seen with conventional spectrum analyzers yet may be degrading system performance. A power spectral density display shows the relative time that RF power is present at all levels and frequencies within the capture span. This is a powerful tool to find interfering signals within the same band as known/wanted signals. The spectrogram displays the maximum output of the RTSA fast Fourier transform (FFT) over time with settable 50 ms to five seconds resolution. The spectrogram provides a history of spectral activity enabling intermittent interferers to be detected and recorded.

Pulse Radar Measurements

The wide bandwidth of the enables detailed analysis of pulsed radar signals. In zero span the default bandwidth is 40 MHz and the minimum sweep time is 60 ns, with pulse rise time measurements as short as 20 ns. Up to 12 markers can be positioned on the traces to simplify pulse repetition, pulse width, and rise time measurements. In zero span a fixed frequency IF output option is also available to interface with external analysis tools. To get fully automated pulse characterization with measurements made in compliance with IEEE Std 181-2011, section 5.2.1 add pulse analyzer Option 421.



RTSA with Spectrogram Display Provides Detailed Insight into Signal Behavior



Remote Spectrum Monitor MS27201A

LTE Base Station Analyzer (Option 883)

The Remote Spectrum Monitor MS27201A features several measurements for installation and maintenance of LTE, FDD, and TDD radios. The goal of these measurements is to help maximize data rate and capacity with accurate power settings, ensuring low out-of-channel emissions and good signal quality. These attributes help to create a low dropped or blocked call rate, and a good customer experience. LTE sites also play a critical role in most early 5G deployments, acting as the anchor to 5G communications. Cell site technicians or RF engineers can make measurements OTA to spot-check a transmitter's coverage and signal quality without taking the cell site off-line. When the OTA test results are ambiguous, the user can directly connect the device to the base station to check the signal quality and transmitter power.

The Remote Spectrum Monitor MS27201A offers the following LTE measurements:

- Cell ID, Sector ID, Cell Group
- Frequency Error
- Time Offset
- PBCH, RS, and SS Power
- Signal Quality (EVM)
- PBCH
- PDSCH (QPSK, 16QAM, 64QAM, 256QAM)
- MIMO Antenna Power and Time Alignment Error (TAE)
- Adjacent Channel Power (ACP)
- Spectral Emissions Mask (SEM)
- Channel Power
- UL/DL Interference
- Channel Spectrum
- Time Alignment Error
- Resource Block Usage
- OFDM Symbol Transmit Power (OSTP)
- Carrier Aggregation
- Multi-PCI Scanner
- Control Channel Measurements
- Constellation Diagrams for PBCH and PDSCH (up to 256QAM)

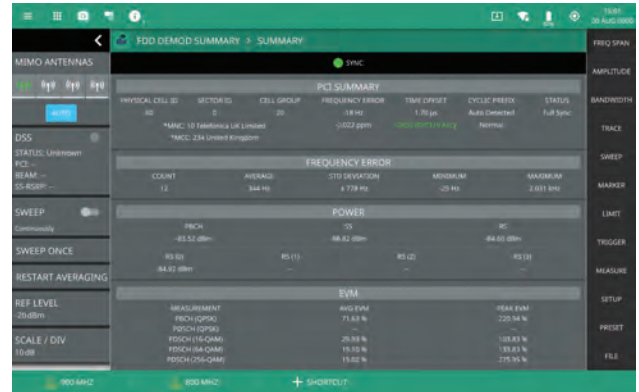

LTE Results Summary Display

Remote Spectrum Monitor MS27201A

5G NR Base Station Measurements (Option 888)

The rapid introduction of 5G NR networks requires an instrument that can validate the performance of the gNB base stations quickly in a field environment. In both the 3.5 GHz and (mmWave) 28/39 GHz bands, the adoption of active antenna systems means that new test methods need to be considered. Some radios may have test monitor ports integrated, but many operators will make gNB transmitter measurements OTA.

The Remote Spectrum Monitor MS27201A high-performance spectrum analyzer performs the essential measurements in full compliance with the 3GPP TS 38.104 V15. Measurements supported include:

-
- | | | |
|-----------------------------|--|---|
| • PCI Cell/Sector ID | • SS-RSRP/RSRQ/SINR/RSSI | • OTA Multi PCI Scanner |
| • Frequency Error | • Channel Power | • EIRP |
| • Time Offset | • Occupied Bandwidth | • TDD Uplink Interference with Gated Spectrum |
| • Difference in Time Offset | • Adjacent Channel Leakage Ratio | • Spectral Emissions Mask (SEM) |
| • Modulation Quality (EVM) | • Transmitter Spurious Carrier Aggregation | • SIB Decoding of MCC and MNC |
| • PBCH Constellation | | |
-

A key part of 5G NR signals is the synchronization signal block (SSB). Decoding the SSB can reveal the important cell characteristics, like cell ID, frequency error, and beam powers. Making measurements on the SSB allows transmitter testing on a live gNB. As well as displaying beam ID, the RSRP is graphed for each of the beams in the SSB. In order to properly decode the signal, the user must know center frequency, bandwidth, and subcarrier spacing of the signal under test. This can be entered manually or by using a 3GPP-defined band and absolute radio-frequency channel number (ARFCN). It is also critical to know the frequency position of the SSB relative to the center frequency of the signal. This can also be entered manually as an offset from center or by entering the global synchronization channel number (GSCN). In cases where the SSB location is unknown, the Remote Spectrum Monitor MS27201A has an Auto SSB Detect feature that searches the 3GPP-defined raster of potential SSB positions to find it automatically. In some cases, especially in mmWave, a single transmitter can be transmitting up to eight carriers simultaneously. The Remote Spectrum Monitor MS27201A has a carrier aggregation feature that allows up to eight individual carriers to be set up and measured sequentially in a loop to ensure all are working correctly.

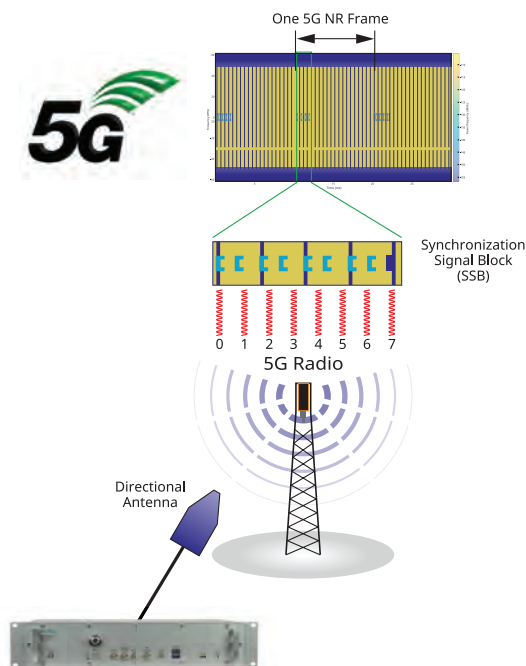

Remote Spectrum Monitor MS27201A Displays RSRP vs Beam Index Based on OTA Analysis of the 5G NR SSB

Remote Spectrum Monitor MS27201A

Remote Spectrum Monitor MS27201A Interfaces

The Remote Spectrum Monitor MS27201A comes standard with: 2 x USB 3.0 type A host ports and a high speed Data Out port. USB ports provide for saving of screen images as a .png, saving IQ data files, IQ data streaming, and facilitate software or option updates. The Data Out port is used for high-speed IQ streaming. Integrated rack mount flanges on the case simplify installation into standard 19-inch rack systems and the low power consumption and air cooling allow for integration immediately adjacent to other instruments maximizing space efficiency.

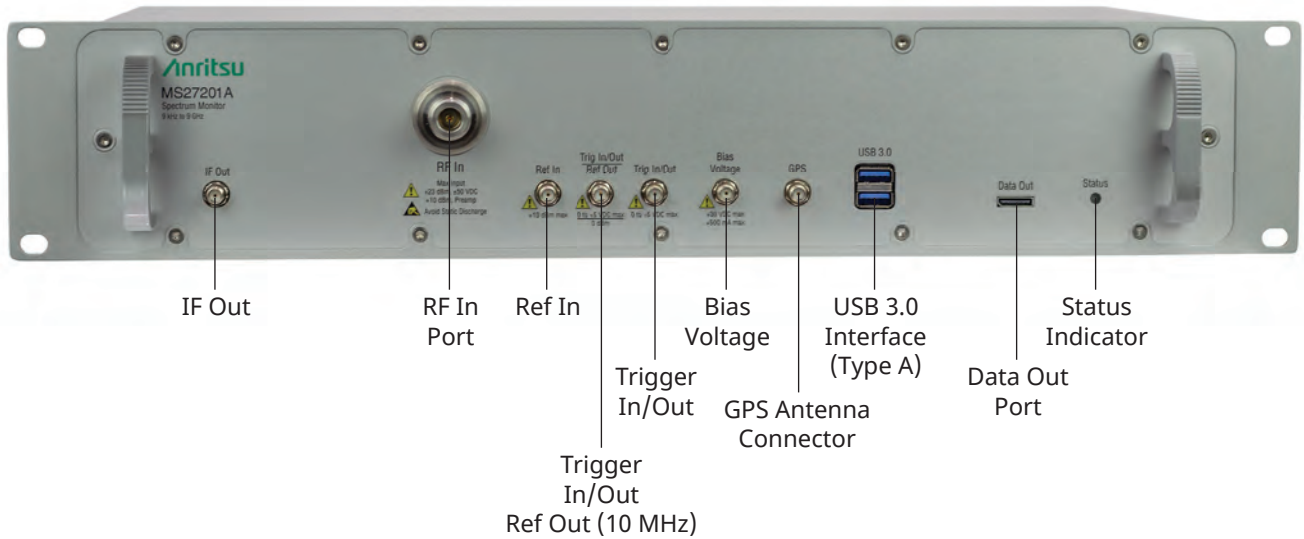

Ordering Information

Part Number	Description
MS27201A	Remote Spectrum Monitor (requires Option 709, 714, 720, 726, 732, 743 or 754)
Options	
MS27201A-0709	Frequency Range 9 kHz to 9 GHz
MS27201A-0714	Frequency Range 9 kHz to 14 GHz
MS27201A-0720	Frequency Range 9 kHz to 20 GHz
MS27201A-0726	Frequency Range 9 kHz to 26.5 GHz
MS27201A-0732	Frequency Range 9 kHz to 32 GHz
MS27201A-0743	Frequency Range 9 kHz to 43.5 GHz
MS27201A-0754	Frequency Range 9 kHz to 54 GHz
MS27201A-006	Remove Wi-Fi and Bluetooth
MS27201A-007	Secure Data
MS27201A-0017	Secure Communication
MS27201A-0027	Channel Scanner
MS27201A-0031	GNSS Receiver (requires antenna, sold separately)
MS27201A-0089	Zero Span IF Output
MS27201A-0090	Gated Sweep
MS27201A-0103	55 MHz Analysis Bandwidth
MS27201A-0104	120 MHz Analysis Bandwidth
MS27201A-0105	150 MHz Analysis Bandwidth
MS27201A-0124	IQ Waveform Capture (includes MX280005A IQ Signal Master base feature set)
MS27201A-0125	IQ Waveform Streaming (includes MX280005A IQ Signal Master base feature set) (requires Option 124)
MS27201A-0126	IQ Waveform Capture (includes MX280005A IQ Signal Master base feature set) (non-export controlled)
MS27201A-0127	IQ Waveform Streaming (includes MX280005A IQ Signal Master base feature set) (requires Option 126, non-export controlled)
MS27201A-0128	Enable Vector Signal Analysis (requires Option 126)
MS27201A-0199	Real-Time Spectrum Analyzer
MS27201A-0400	Enable Vision Monitor
MS27201A-0401	Enable Vision Locate
MS27201A-0407	Enable Vision High-Speed Port Scanner
MS27201A-0421	Pulse Analyzer
MS27201A-0509	AM/FM Modulation Measurement
MS27201A-0871	WCDMA FDD Measurement (requires Option 31)
MS27201A-0883	LTE FDD/TDD Measurements (requires Option 31)
MS27201A-0888	5G NR Downlink Measurements (requires Option 31)
MS27201A-xxxx-0097	Accredited Calibration to ISO17025 and ANSI/NCSL Z540-1, includes calibration certificate, test report, and uncertainty data
MS27201A-xxxx-0098	Accredited Calibration to ISO17025 and ANSI/NCSL Z540-1, includes calibration certificate, test report, and uncertainty data
MS27201A-xxxx-0099	Premium Calibration to ISO17025 and ANSI/NCSL Z540-1, includes calibration certificate, test report, and uncertainty data (xxxx is the frequency option number)
Supporting Software	
MX280005A	IQ Signal Master™ Vector Modulation Analysis
MX280001A	Vision™ Monitor
ARRT	Anritsu Remote and Report Tools

For a full list of all accessories for the Remote Spectrum Monitor MS27201A, please refer to the Technical Data Sheet (P/N 11410-02833).

• **United States**

Anritsu Americas Sales Company

490 Jarvis Drive, Morgan Hill, CA 95037-2809, U.S.A.
Phone: (408)-778-2000

• **Canada**

Anritsu Electronics Ltd.

Americas Sales and Support

490 Jarvis Drive, Morgan Hill, CA 95037-2809, U.S.A.
Phone: +1-800-Anritsu (1-800-267-4878)

• **Brazil**

Anritsu Eletrônica Ltda.

Praça Amadeu Amaral, 27 - 1 Andar
01327-010 - Bela Vista - Sao Paulo - SP, Brazil
Phone: +55-11-3283-2511

• **Mexico**

Anritsu Company, S.A. de C.V.

Bldv Miguel de Cervantes Saavedra #169 Piso 1, Col. Granada
Mexico, Ciudad de Mexico, 11520, MEXICO
Phone: +52-55-4169-7104

• **United Kingdom**

Anritsu EMEA Limited

900 Capability Green, Luton, Bedfordshire, LU1 3LU, U.K.
Phone: +44-1582-433200

• **France**

Anritsu SA

12 avenue du Québec, Immeuble Goyave,
91140 VILLEBON SUR YVETTE, France
Phone: +33-1-60-92-15-50

• **Germany**

Anritsu GmbH

Nemetschek Haus, Konrad-Zuse-Platz 1,
81829 München, Germany
Phone: +49-89-442308-0

• **Italy**

Anritsu S.R.L.

Spaces Eur Arte, Viale dell'Arte 25, 00144 Roma, Italy
Phone: +39-6-509-9711

• **Sweden**

Anritsu AB

Kistagången 20 B, 2 tr, 164 40 Kista, Sweden
Phone: +46-8-534-707-00

• **Finland**

Anritsu AB

Technopolis Aviapolis, Teknobulevardi 3-5 (D208.5.),
FI-01530 Vantaa, Finland
Phone: +358-20-741-8100

• **Denmark**

Anritsu A/S

c/o Regus Winghouse, Ørestads Boulevard 73, 4th floor,
2300 Copenhagen S, Denmark
Phone: +45-7211-2200

• **Spain**

Anritsu EMEA GmbH

Representation Office in Spain

Calle Manzanares 4, Primera planta, 28005 Madrid, Spain
Phone: +34-91-572-6761

• **Austria**

Anritsu EMEA GmbH

Am Belvedere 10, A-1100 Vienna, Austria
Phone: +43-(0)1-717-28-710

• **United Arab Emirates**

Anritsu A/S

Office No. 164, Building 17, Dubai Internet City
P. O. Box – 501901, Dubai, United Arab Emirates
Phone: +971 (0) 4-2424919

• **India**

ANRITSU INDIA PRIVATE LIMITED

6th Floor, Indiqueb ETA, No.38/4, Adjacent to EMC2,
Doddanekundi, Outer Ring Road, Bengaluru – 560048, India
Phone: +91-80-6728-1300
Fax: +91-80-6728-1301

• **Singapore**

ANRITSU PTE LTD

1 Jalan Kilang Timor, #07-04/06 Pacific Tech Centre
Singapore 159303
Phone: +65-6282-2400

• **Vietnam**

ANRITSU COMPANY LIMITED

16th Floor, Peakview Tower, 36 Hoang Cau Street, O Cho Dua Ward,
Hanoi, Vietnam
Phone: +84-24-3201-2730
Fax: +84-24-3201-2740

• **P.R. China (Shanghai)**

Anritsu (China) Co., Ltd.

Room 2301-2303, Tower A, New Caohejing International Business
Center No. 391 Gui Ping Road, Shanghai, 200233, P.R. China
Phone: +86-21-6237-0898

• **P.R. China (Hong Kong)**

ANRITSU COMPANY LIMITED

Unit 1302, 13th Floor, New East Ocean Center,
No.9 Science Museum Road, TsimShaTsui East,
Kowloon, Hong Kong
Phone: +852-2301-4980

• **Japan**

ANRITSU CORPORATION

8-5, Tamura-cho, Atsugi-shi, Kanagawa, 243-0016 Japan
Phone: +81-46-296-1244
Fax: +81-46-296-1239

• **Korea**

Anritsu Corporation Limited

8F, A TOWER, 20, Gwacheondaero 7-gil, Gwacheon-si,
Gyeonggi-do, 13840, Republic of Korea
Phone: +82-2-6259-7300

• **Australia**

Anritsu Pty Ltd

Unit 20, 21-35 Ricketts Road, Mount Waverley, Victoria 3149, Australia
Phone: +61-3-9558-8177

• **Taiwan**

ANRITSU COMPANY, INC.

7F, No. 316, Sec. 1, NeiHu Rd., Taipei 114, Taiwan
Phone: +886-2-8751-1816

List Revision Date: 20251202



Anritsu utilizes recycled paper and environmentally conscious inks and toner.



© Anritsu All trademarks are registered trademarks of their respective owners. Data subject to change without notice. For the most recent specifications visit: www.anritsu.com

11410-02861, Rev. L Printed in United States 2025-12
©2025 Anritsu Company. All Rights Reserved.



崑崙有限公司

802626 高雄市苓雅區新光路38號5樓之1
電話：07-5368282 傳真：07-5368272

WEWANT Co., Ltd.

5F.-1, No.38, Xinguang Rd., Lingya Dist.,
Kaohsiung City 802, Taiwan (R.O.C.)
TEL: +886-7-5368282 FAX: +886-7-5368272

